



The DTG-1 is an economical source of a variety of audio test signals that are generated entirely in the digital domain and output in the AES/EBU format. Use it in the studio as a reference tone generator or on the bench as a troubleshooting tool. Rugged, compact, and capable of running off battery power, the DTG-1 is also ideal for portable applications. The DTG-1 has internal oscillators for both 44.1 and 48kHz sample rates, or it may be locked to an external reference. The DTG-1 has all the adjustments needed to make isolation of digital transmission problems simple and easy to find. Like all of the modules in the SoundPals™ line, the DTG-1 is housed in a compact, rugged aluminum enclosure.

**Now!
7 Year
Warranty
on
SoundPals**

NAB-97 Pick Hit Awards
Awarded to
Graham-Patten SoundPals
for

Outstanding Technical Achievement

DTG-1 Digital Test Generator

Features:

- **Switch selectable output signals including:**
 - sine waves at 6 pre-programmed frequencies
 - 1 kHz tone with L/R channel ID
 - phase ID
 - sine wave frequency / amplitude sweep /step
 - white noise
 - pink noise
 - silence
- **Level of test signals is adjustable from 0 to -60dBFS**
- **Front panel dipswitch for setting channel status bits (professional and consumer modes) and operating mode**
- **Both XLR (AES3) and BNC (AES3id) output connectors with voltage level adjustments**
- **Internal oscillators for 44.1 and 48kHz sample rates**
- **External reference input for word clock or AES3id signal**
- **AES3id reference input may be passed through to the AES output with channel status modification**
- **Compact size:
5.2"W x 1.62"H x 6.625"D
(15.2 x 4.1 x 16.8 cm)
less connectors**

TECHNICAL DATA

Output impedance	110Ω balanced (XLR output) 75Ω unbalanced (BNC output)
Output level (XLR output)	4.5Vp-p, adjustable in 3dB steps down to 400mV (-21dB)
Output level (BNC output)	1Vp-p, adjustable in 3dB steps down to 90mV (-21dB)
Audio resolution	Switch selectable to 16, 20, or 24-bits
Audio waveform amplitude	Switch selectable to eight preset values from 0 to -60dBFS and LSB only
Audio waveforms selectable	20Hz, 100Hz, 440Hz, 1kHz, 3kHz and 10kHz sine waves, 1kHz tone with L/R channel ID, phase ID, sine wave frequency / amplitude sweep/step, white noise, pink noise, silence.
Output waveform dither	Switch selectable 1 LSB TPDF output dither
Internal reference	Switch selectable to 44.1 or 48kHz
External reference input	AES3id or word clock, Fs=30 to 50kHz
Power	150mA @ 6Vdc

OPTIONS

RT-2	1RU rack tray for mounting up to 3 units with power supply
PSU-1	90-260V 50/60Hz in-line power supply with detachable IEC power cord



APPLICATION DIAGRAMS

There are many uses for SoundPals in music recording, radio or television broadcasting, DVD/CD/CR-ROM mastering, and video production and post-production.

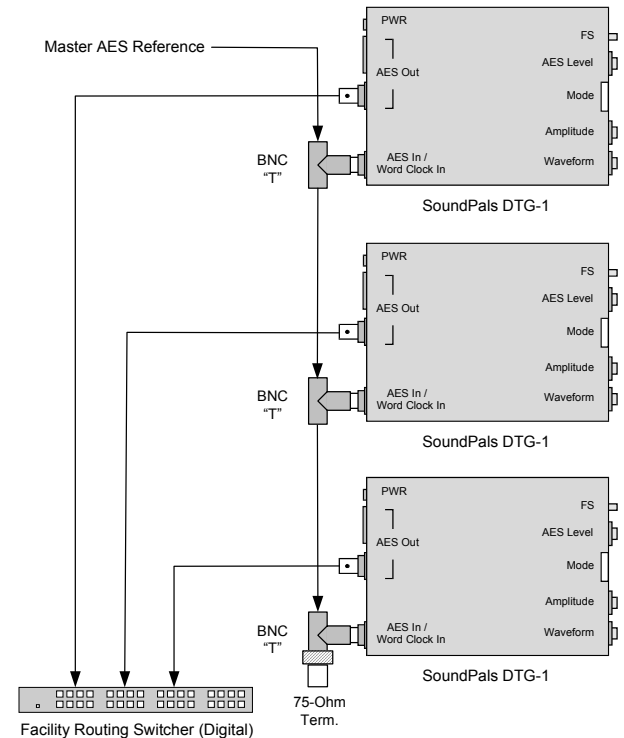

The diagram illustrates a typical application in which three DTG-1 modules, all locked to a common reference, are used to generate test signals that are distributed using a centralized routing switcher. This arrangement provides three different types of test signals – silence, tone, and sweep, for example – as synchronous AES sources that are available throughout the facility.

Your local Graham-Patten Distributor: