

ADC-24 User Guide

Stereo A-to-D Converter



GRAHAM-PATTEN
SoundPals



Printing History

SoundPals™ ADC-24 A-to-D converter

Rev. N/C

March 2007

Printed in U.S.A.

Part Number **08-2045-00**

The information contained in this guide is subject to change without notice or obligation.

Copyrights and Trademarks

© 2005 GRAHAM-PATTEN SYSTEMS, INC.

Contents of this publication may not be reproduced in any form without the written permission of Graham-Patten. Reproduction or reverse engineering of copyrighted software is prohibited.

FCC Compliance

This equipment has been tested and found to comply with the limits for a Class A digital device pursuant to Part 15 of the FCC Rules. These limits are designed to provide reasonable protection against harmful interference when the equipment is operated in a commercial environment. This equipment generates, uses, and can radiate radio frequency energy and, if not installed and used in accordance with the instruction manual, may cause harmful interference to radio communications. Operation of this equipment in a residential area is likely to cause harmful interference in which case the user will be required to correct the interference at your own expense.

Warranty Statement

Graham-Patten warrants that the equipment it manufactures is free from defects in workmanship and materials and meets applicable published specifications. Equipment that has been operated within published ratings and has not been subjected to abuse or modification, and which fails because of such defects, will be replaced or repaired at the Company's discretion if it is returned, freight prepaid, to Graham-Patten within seven years of receipt.

This warranty supersedes all other Warranties, express or implied. Graham-Patten is not liable for any consequential damages.

Company Address



GRAHAM-PATTEN SYSTEMS, INC.
119 East McKnight Way, Unit A
Grass Valley, California 95949
Telephone: (888) 622-4747, (530) 477-2984
Fax: (530) 477-2986
e-mail: info@isis-group.com
World Wide Web: www.gpsys.com

Graham-Patten is a division of



Table of Contents

Table of Contents	ii
Introduction	1
What are SoundPals?.....	1
Documentation Conventions.....	1
Signals and Values.....	1
Warnings.....	1
Unpacking and Inspection	2
Power Supply Note	2
ADC-24	3
About the ADC-24.....	3
ADC-24 Installation.....	5
Connecting Power	5
Connecting Inputs	5
Connecting AES Reference	5
Connecting Outputs.....	5
ADC-24 Operation	6
ADC-24 Interconnection	7
Basic - Inserting Analog Equipment.....	7
Basic - Analog Input to Digital Mixer	7
Advanced - Multiple Analog Inputs to Digital Mixer.....	8
ADC-24 Internal Jumpers	9
ADC-24 Troubleshooting	11
ADC-24 Specifications.....	12
Audio Specifications	12
Environmental Specifications and Dimensions.....	12
Inside the Module	13
In This Section	13
Before You Begin.....	13
Opening the Module	13
Closing the Module.....	13
External Power	14
About Power Supplies	14
CE Compliance.....	14
Portable Power Sources.....	14
Power Supply Specifications	14
Power Supply Sources	15

Introduction

What are SoundPals?

Each Graham-Patten SoundPals module is essentially a digital audio *building block* that can be used independently, or interconnected to perform more advanced mixing and audio processing functions.

SoundPals can be used in both standalone and system configurations:

- In a “standalone” configuration, each SoundPals module is designed to perform a specific audio processing function such as ADAT-to-Analog conversion. In this way, each module functions as a perfect low-cost adjunct to larger mixing consoles (such as the Graham-Patten D/ESAM series) — for single-purpose processing tasks.
- In a “system” configuration, SoundPals can be *linked* to form more comprehensive digital audio tools. For field recording, studio applications, and workstation applications, SoundPals can be used to seamlessly perform functions that would otherwise require extensive peripheral gear. Best of all, SoundPals “systems” can be re-configured quickly and easily — to suit your changing audio production requirements.

All SoundPals modules are extremely compact, rugged, and identical in size for ease of installation, interconnection, and use. In addition, SoundPals support AES3id. This allows longer, more robust AES signal distribution using standard coaxial cable. Error free distances of 1000 feet can be attained using inexpensive coaxial cables.

Documentation Conventions

The following documentation conventions are used in this guide:

- Buttons, knobs, connectors, and switches are indicated in bold-faced capital letters. For example:

Adjust the left **GAIN TRIM** to ...

- Primary sections are listed in bold text, with a line above:

Primary Section

- Secondary sections are listed in bold text, with no line:

Secondary Section

Signals and Values

Note the following important information regarding audio signal level:

- 0dBu = 0.778Vrms
- AES3 = Balanced output with 2 channels of digital audio (left and right)
- AES3id = Unbalanced output with 2 channels of digital audio (left and right)

Warnings

Please observe the following important warnings:

- Heed all warnings on the unit and in the instructions.
- Do not use this product in or near water.
- Route power cords and other cables so that they are not likely to be damaged. Disconnect power before cleaning. Do not use liquid or aerosol cleaners; use only a damp cloth.

Unpacking and Inspection

When you receive your SoundPals modules, inspect the cartons for signs of damage. Contact your dealer and the shipper *immediately* if you suspect any damage has occurred during shipping. Check the contents of each box to be sure that all parts are included. If any items are missing, contact your dealer immediately.

Power Supply Note

SoundPals are delivered with a power connector *only*. A separate power supply must be obtained. Graham-Patten offers several power solutions for both domestic and international customers. Refer to “**External Power**” for detailed power specifications for users who wish to configure their own power source, rather than purchase one from Graham-Patten.

ADC-24

About the ADC-24

The SoundPals ADC-24 is a stereo 24-bit, analog-to-digital AES converter. The unit takes two line-level analog inputs (on XLR connectors), and converts them to one digital AES output (provided on both XLR and BNC connectors simultaneously).

The ADC-24 offers the following features:

- 24-bit A/D converter
- Adjustable level for each input (-10 to +4 dBu at -20 dBFS)
- AES reference input
- Significant status bits selectable with internal dipswitch
- Active balanced and unbalanced outputs
- LED level indicators for normal and overload conditions
- Optional rack mounting tray (1 RU)
- Compact size, rugged construction

Two versions of the ADC-24 are available:

- **44.1 kHz Model**

This model defaults to 44.1 kHz, via the internal crystal. However, if an external reference is applied to the **AES REF** connector, the output frequency will lock to the reference.

- **48 kHz Model**

This model defaults to 48 kHz, via the internal crystal. However, if an external reference is applied to the **AES REF** connector, the output frequency will lock to the reference.

NOTE The printed legend on the rear panel indicates the default frequency.

The figure below illustrates the ADC-24's front panel:

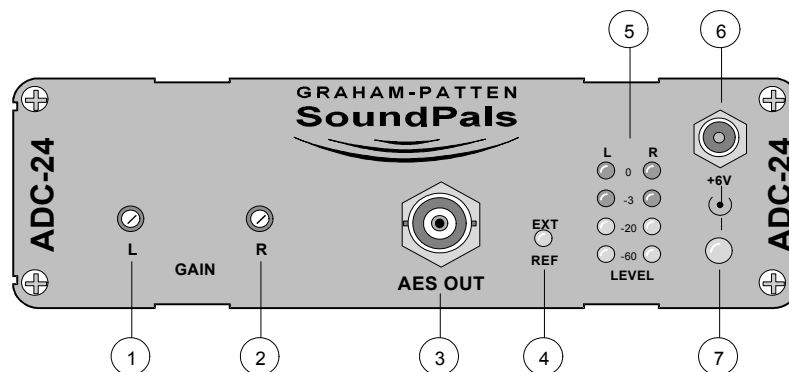

- 1) **Left Analog Input Gain Trim** — **L GAIN** sets the left channel's analog input level (the level that you want to correspond to -20dB below digital clipping).
- 2) **Right Analog Input Gain Trim** — **R GAIN** sets the right channel's analog input level (the level that you want to correspond to -20dB below digital clipping).
- 3) **AES Unbalanced Output** — provides AES unbalanced output (BNC). Output is concurrent with the rear panel's AES balanced output (XLR) — both can be used simultaneously.

- 4) **AES Reference LED** — the **EXT REF** LED lights when the sampling frequency is locked to the *externally supplied* AES reference signal. The LED is an indication only, not an alarm.
- 5) **Level Indicator LEDs** — provides level indication for each input (calibrated in dB). When properly adjusted, the following levels are indicated:
 - **-60 dB**: signal present
 - **-20 dB**: normal digital reference level
 - **-3 dB**: approaching clipping
 - **0 dB**: A/D converter is clipping
- 6) **Power Connector** — accepts the power jack from the 6 VDC power supply. Refer to “**External Power**” for more information regarding external power.
- 7) **Power LED** — the large green LED below the power jack lights when power is applied.

The figure below illustrates the ADC-24’s rear panel:

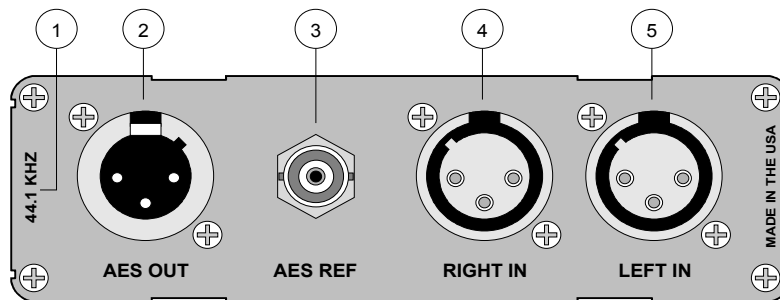

- 1) **ADC Version** — the printed legend indicates the default frequency (either 44.1 kHz or 48 kHz).
- 2) **AES Balanced Output** — provides AES balanced output via XLR connector. Output is concurrent with the front panel’s AES unbalanced output (BNC) — both can be used simultaneously.
- 3) **AES Reference Input** — the **AES REF** connector accepts an AES reference signal (between 30 kHz and 50 kHz sampling rate). Only timing information is used; audio content (if any) is ignored. Refer to the “**Connecting AES Reference**” section for information on switching frequencies via the reference signal.
- 4) **Right Analog Input** — accepts right channel line level analog input. The input level is adjustable via **R GAIN** on the front panel of the ADC.
- 5) **Left Analog Input** — accepts left channel line level analog input. The input level is adjustable via **L GAIN** on the front panel of the ADC.

ADC-24 Installation

This section provides instructions for connecting power, analog inputs, AES reference, and digital outputs.

Connecting Power

Plug a 6VDC power supply into the appropriate voltage outlet for *your specific country*, and connect the end of the cord into the ADC-24 jack marked **+6V**. Secure the locking ring finger tight. The green LED below the jack lights when power is applied.

Connecting Inputs

Connect left and right channel analog inputs to the two rear connectors marked **LEFT IN** and **RIGHT IN**. Balanced sources are connected to pins 2 (+) and 3 (-) with pin 1 and the shell grounded. Unbalanced sources are connected to pin 2 with pins 1, 3 and the shell grounded. Refer to the “**ADC-24 Operation**” section for instructions on correctly adjusting input level.

Connecting AES Reference

The ADC-24 can be synchronized to an alternate output frequency (from the default frequency) by connecting a valid AES reference signal to the **AES REF** BNC connector. The **EXT REF** LED on the front panel lights when a valid reference signal is applied.

To phase lock the unit's sample frequency to a reference, connect a reference signal (between 30 kHz and 50 kHz sampling rate) to the **AES REF** BNC connector. The AES signal output will now phase-lock to the incoming reference — independent of the ADC's default reference frequency.

Note that the **AES REF** input is normally terminated internally with 75Ω. When it is necessary to loop reference to several SoundPals, the signal must be terminated only once, and always at the last unit in the chain. Refer to the “**ADC-24 Internal Jumpers**” section for information on changing the input from terminating to bridging.

Connecting Outputs

Connect the digital audio output from one of the **AES OUT** connectors on the front or rear panel, and route it to the input of the desired destination device. Both AES3 and AES3id outputs may be used simultaneously.

ADC-24 Operation

This section provides instructions for aligning the ADC's inputs with the gain controls.

Using the Gain Controls

For setting the left and right channel analog input levels, each input has its own level adjustment on the front panel. Inputs are factory-set for +4 dBu at -20 dBFS. Use the following alignment procedure to set other levels:

To align the left and right analog outputs:

1. Connect a reference analog tone generator to the ADC-24's **LEFT IN** and **RIGHT IN** connectors.
2. Turn on the reference tone generator, and adjust it to the level that you want to correspond to **-20 dB** below digital clipping.
3. While watching the ADC's front panel **Level Indicator LEDs**, adjust the ADC's **L** and **R GAIN** trimmers — until the **-20 dB** LED just comes on.

This setting provides 20 dB of headroom, based on the selected analog input reference level.

Setting the Sample Frequency

Refer to the “**Connecting AES Reference**” section for instructions on changing the ADC's sample frequency.

ADC-24 Interconnection

This section provides basic and advanced interconnection diagrams.

- **Basic — Inserting Analog Equipment**

In this application, an analog ATR is seamlessly inserted in a digital stream, using both the DAC and ADC together.

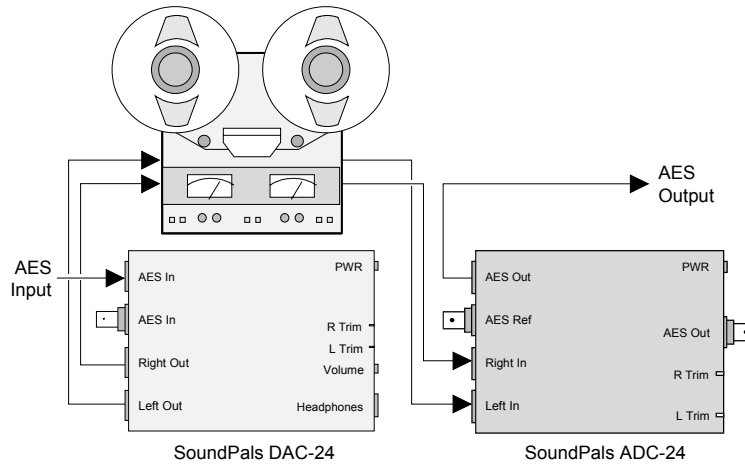

- **Basic — Analog Input to Digital Mixer**

In this application, connect analog inputs (e.g., from an ATR) to the ADC — and the ADC's AES output to the input of a digital mixer. Note how one of the mixer's outputs is used to synchronize the ADC (using the **AES REF** connector).

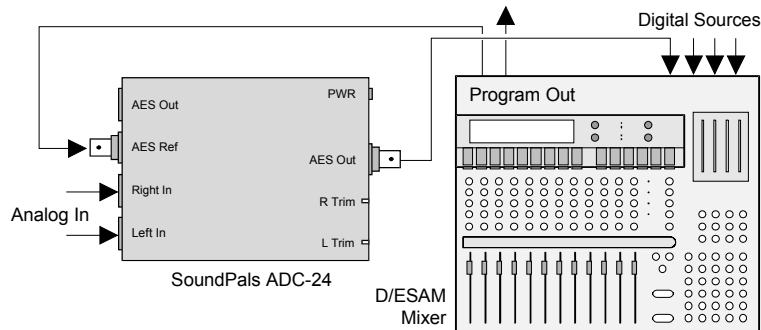

- **Advanced — Multiple Analog Inputs to Digital Mixer**

In this application, ADC and DMIC SoundPals are combined to provide *multiple* analog inputs to a digital mixer.

- ~ An analog ATR feeds an ADC, and then to the mixer via AES.
- ~ Dual mics are converted to digital in the DMIC, and then to the mixer via AES.
- ~ An additional analog signal feeds an ADC, and then to the mixer via AES.
- ~ One of the mixer's outputs is used to synchronize *all* SoundPals (via bridging AES connections).

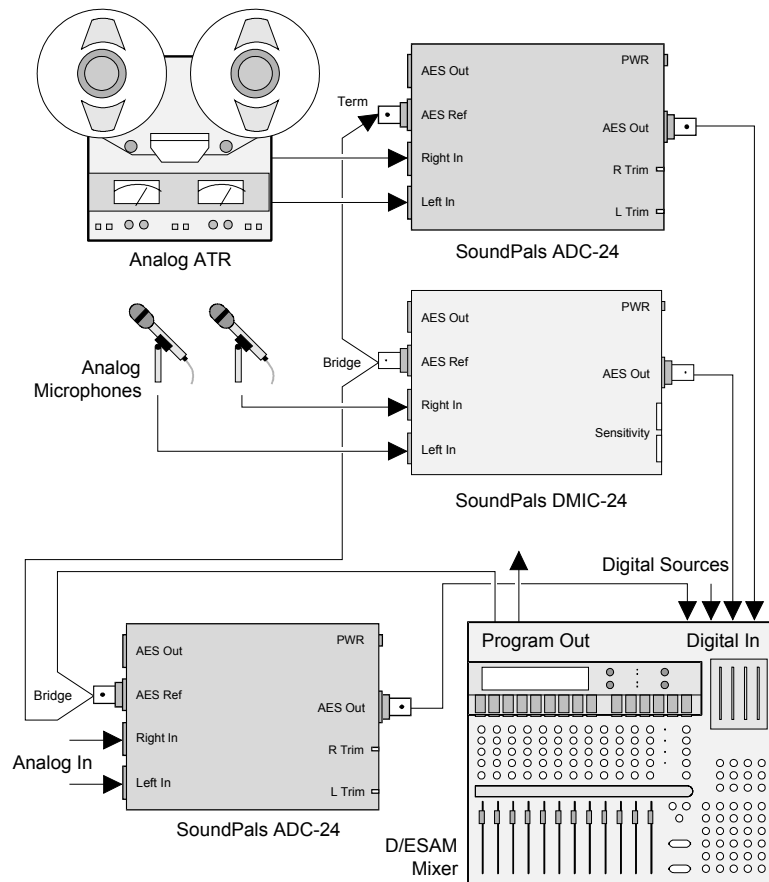

ADC-24 Internal Jumpers

This section provides information about the ADC-24's internal jumpers and adjustments.

NOTE For detailed instructions on opening and closing the ADC-24, see Appendix A, "Inside the Module."

The figure below shows the ADC-24's internal jumper locations:

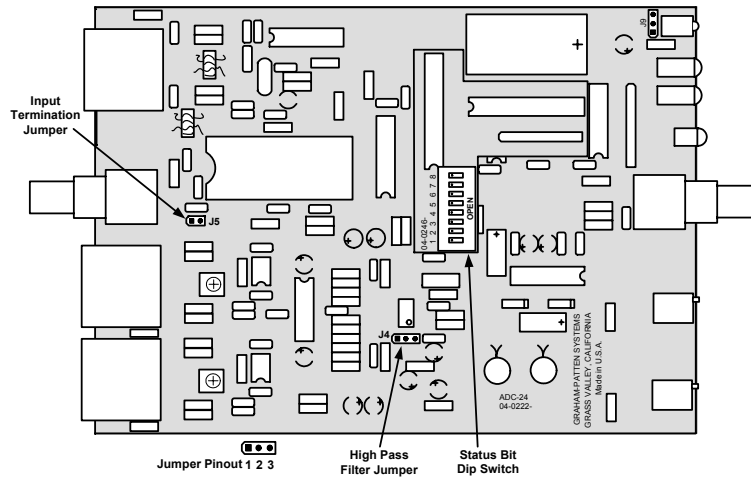

- **J4** is the High Pass Filter jumper. With pins 1 and 2 connected, the filter is disabled. With pins 2 and 3 connected, (factory default) the filter is enabled.
- To change the AES reference input from terminating to bridging, remove jumper **J5**.

SW1 is the **Status Bit Dip Switch** that is used to set the channel status on the AES outputs. The switch is an eight-position DIP, all of which are active. Switch shows default factory switch settings.

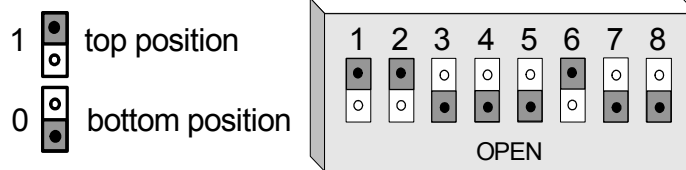

For all switches:

- ~ **0** is open
- ~ **1** is closed

- If Switches **1** and **2** are **Closed**, (factory default) the unit is in the **Professional Mode** and the following switch settings apply.
- Switch **3** defines the **Audio Mode**.

Function	SW3
Audio	0
Non-Audio	1

- Switches **4** and **5** define the **Sample Frequency**.

Function	SW4	SW5
Not Indicated	0	0
48 kHz	1	0
44.1 kHz	0	1
32 kHz	1	1

- Switches **6** and **7** define the **Emphasis**.

Function	SW6	SW7
Not Indicated	0	0
None	1	0
50/51	0	1
CCITT J.17	1	1

- Switch **8** determines the **Channel Mode**.

Function	SW8
Not Indicated	0
Stereo	1

- Switch **5** defines the **Copy Mode**.

Function	SW5
Inhibited	0
Permitted	1

- Switch **6** and **7** defines the **Category Code**.

Function	SW6	SW7
General	0	0
Digital Converter	1	0
Laser, CD	0	1
Magnetic Tape	1	1

- Switch **8** determines the **Generation Table**.

Function	SW8
1 st Generation or Higher	0
Original	1

ADC-24 Troubleshooting

The table below lists several ADC-24 problems, and provides a variety of “checklist” procedures designed to solve them.

Problem	Procedure
No signal at either AES output.	<ul style="list-style-type: none"> • Is power applied? Check power LED and power supply.
No audio on AES output.	<ul style="list-style-type: none"> • Is input connected correctly? Check + to pin 2, or ground to pin 3.
Front panel meters not registering.	<ul style="list-style-type: none"> • Adjust input levels.
Ext Ref indicator not lit on front panel.	<ul style="list-style-type: none"> • Is AES reference connected? Check that an AES signal is applied to the reference input if you want synchronized sampling. • Is the reference input a valid AES signal? • Is the reference input sampling frequency between 30 KHz and 50 KHz?

NOTE Please contact the GPS factory if the problem still exists after completing the above procedures.

ADC-24 Specifications

This section provides audio and environmental specifications.

Audio Specifications

Parameter	Specification
Analog Inputs	
Impedance	>15k Ω
Gain range	-10 dBu to 6 dBu for -20 dBFS output
Frequency Response	+0/-0.1 dB, 20 Hz – 20 KHz
THD+N @ -20dBFS	-91 dB, 20Hz-20 KHz
THD+N @ -1dBFS	-84 dB, 20Hz-20 KHz
Dynamic range	96 dB
CMRR	>60 dB, 20 Hz – 10 KHz
Crosstalk	<-84 dB, 20 Hz – 20 KHz
Digital Outputs	
Terminated	110 Ω AES3, 75 Ω AES3id
Sample Rate	30 KHz – 50 KHz
Output resolution	24 Bit
Options	
RT-2, 1RU rack tray for mounting up to 3 units	
Power supplies:	
<ul style="list-style-type: none">• PSU-1, 90-260V 50/60Hz in-line power supply with detachable IEC power cord (preferred)• PS-2A, 220V/50Hz wall mount power supply• PS-3A, 115V/60Hz wall mount power supply	

- NOTE**
- All specifications listed above subject to change without notice.
 - All parameters listed above specified at 48 kHz sampling frequency.

Environmental Specifications and Dimensions

Parameter	Specification
Dimensions (less connectors)	5.2W x 1.62H x 6.625D 13.2 x 4.1 x 16.8 cm
Power	300 mA @ 6Vdc
Operating Temp.	10 – 50 °C
Operating Humidity	10 – 90% RH non-condensing

Inside the Module

In This Section

This section provides instructions for opening and closing the SoundPals ADC-24 module to gain access to the internal circuit board.

NOTE The internal circuit board should only be removed from the module if you want to set the termination jumper, the High Pass Filter jumper or the Status Bit dip switch.

Before You Begin

Check the following items before opening the module and attempting to remove the internal circuit board:

- If required, remove the SoundPals module from the rack tray.
- Disconnect the power supply from the front of the product.
- Disconnect all input and output cables.
- Perform the remaining steps *only* in a static free environment. Make sure that *you and the product* are both grounded.

The following tools are required:

- #2 Philips screwdriver

Opening the Module

Use the following steps to open the ADC-24 SoundPals module:

1. On the rear panel, remove the four Phillips screws from the four corners of the module.
2. On the rear panel, remove all Philips XLR mounting screws from the module.
3. On the rear panel remove the BNC nut and associated lock washer.
4. Remove the rear panel.
5. On the front panel, remove four Phillips screws from the four corners of the module.
6. Pulling the front panel, carefully draw the internal circuit board and front panel assembly from the housing.

CAUTION Keep the case horizontal so that the BNC bushing stays with the connectors.

7. Set the housing and all mounting hardware in a safe place.

Closing the Module

Use the following steps to close the ADC-24 SoundPals module:

1. Ensure that product label is on the bottom.
2. Carefully slide the internal circuit board and front panel assembly through the housing. Keep the case horizontal so that the BNC bushing stays with the connectors.
3. Replace, but do not tighten, the four Phillips screws in the front corners of the SoundPals module.
4. Replace the rear panel.
5. Replace, but do not tighten, the four Phillips screws in the rear corners of the SoundPals module.

6. Tighten the four front plate corner screws making sure that the plate is aligned with the housing. Repeat with the four rear plate corner screws.
7. Replace all Philips XLR mounting screws at the rear of the SoundPals module.
8. Replace the BNC nut and associated lock washer at the rear of the SoundPals module.

CAUTION Do not over tighten the screws.

External Power

About Power Supplies

An external power supply conforming to the specifications listed in the following “**Power Supply Specifications**” section *must be used* to guarantee that published SoundPals performance figures are met. Any power supply meeting these specifications will supply adequate power for a single SoundPals module. Although the specification is written for power supplies running from AC line inputs, DC (battery) sources may be used if they meet all of the listed requirements.

CE Compliance

For CE compliance, the power supply that you use *must comply* with the following requirements:

- Low Voltage Directive 73/23/EEC
- EMC Directive 89/336/EEC
- EMC Directive 93/68/EEC
- The connector locking ring must be tight.

Portable Power Sources

For portable SoundPals power sources, sealed lead-acid, nickel cadmium or alkaline primary batteries may be used. However, the maximum voltage must *not* exceed 8.6 volts, and a minimum of 5.6 volts is required for normal operation. Maximum current drain will be 325mA.

Power Supply Specifications

The following specifications must be met over all anticipated operating conditions including AC power line range, temperature range, etc.

Parameter	Specification
Output voltage	5.6V minimum (measured at trough of ripple) at 321mA constant current. 8.6V maximum (measured at peak of ripple) at 210 mA constant current.
Ripple voltage	2V p-p at 700mA constant current. 400mV p-p at 700mA constant current with external 2200 μ F capacitor.
Connector	Switchcraft 761K with center positive, sleeve negative.

Power Supply Sources

In addition to the GPS-supplied universal power supply, the following power supplies meet the SoundPals requirements:

Company	Model	Note
Stancor	STA-4860	120V AC, 60 Hz
Stancor	STAF-0797F	220V AC, 50 Hz with European wall plug (CE compliant).
Elpac	MI2007	95-250V AC, 47-63 Hz with IEC inlet (line cord required). Will power up to six units (CE compliant).