Printing History

SoundPals™ ADLY-4/B AES3id Audio Delay

Rev. N/C

March 2007

Printed in U.S.A.

Part Number **08-2056-00**

The information contained in this guide is subject to change without notice or obligation.

Copyrights and Trademarks

© 2005 GRAHAM-PATTEN SYSTEMS, INC.

Contents of this publication may not be reproduced in any form without the written permission of Graham-Patten. Reproduction or reverse engineering of copyrighted software is prohibited.

FCC Compliance

This equipment has been tested and found to comply with the limits for a Class A digital device pursuant to Part 15 of the FCC Rules. These limits are designed to provide reasonable protection against harmful interference when the equipment is operated in a commercial environment. This equipment generates, uses, and can radiate radio frequency energy and, if not installed and used in accordance with the instruction manual, may cause harmful interference to radio communications. Operation of this equipment in a residential area is likely to cause harmful interference in which case the user will be required to correct the interference at your own expense.

Warranty Statement

Graham-Patten warrants that the equipment it manufactures is free from defects in workmanship and materials and meets applicable published specifications. Equipment that has been operated within published ratings and has not been subjected to abuse or modification, and which fails because of such defects, will be replaced or repaired at the Company's discretion if it is returned, freight prepaid, to Graham-Patten within seven years of receipt.

This warranty supersedes all other Warranties, express or implied. Graham-Patten is not liable for any consequential damages.

Company Address



GRAHAM-PATTEN SYSTEMS, INC.
119 East McKnight Way, Unit A
Grass Valley, California 95949
Telephone: (888) 622-4747, (530) 477-2984
Fax: (530) 477-2986
e-mail: info@isis-group.com
World Wide Web: www.gpsys.com

Graham-Patten is a division of



Table of Contents

Table of Contents	ii
Introduction	1
What are SoundPals?.....	1
Documentation Conventions.....	1
Signals and Values.....	1
Warnings.....	1
Unpacking and Inspection.....	2
Power Supply Note.....	2
ADLY-4/B	3
About the ADLY-4/B.....	3
ADLY-4/B Installation.....	5
Connecting Power.....	5
Connecting the Reference Input.....	5
Connecting the AES Waveform Inputs.....	5
Connecting the AES Waveform Outputs.....	5
ADLY-4/B Operation.....	6
Using the Video Frame Reference Rate Switch.....	6
Using the Frame Delay Switches.....	6
Using the Reference Selector Switch.....	6
ADLY-4/B Interconnection.....	8
ADLY-4/B Troubleshooting.....	9
ADLY-4/B Specifications.....	10
Audio Specifications.....	10
Environmental Specifications and Dimensions.....	11
Inside the Module	11
In This Section.....	11
Before You Begin.....	11
Opening the Module.....	11
Closing the Module.....	11
External Power	12
About Power Supplies.....	12
CE Compliance.....	12
Portable Power Sources.....	12
Power Supply Specifications.....	12
Power Supply Sources.....	13

Introduction

What are SoundPals?

Each Graham-Patten SoundPals module is essentially a digital audio *building block* that can be used independently, or interconnected to perform more advanced mixing and audio processing functions.

SoundPals can be used in both standalone and system configurations:

- In a “standalone” configuration, each SoundPals module is designed to perform a specific audio processing function such as ADAT-to-Analog conversion. In this way, each module functions as a perfect low-cost adjunct to larger mixing consoles (such as the Graham-Patten D/ESAM series) — for single-purpose processing tasks.
- In a “system” configuration, SoundPals can be *linked* to form more comprehensive digital audio tools. For field recording, studio applications, and workstation applications, SoundPals can be used to seamlessly perform functions that would otherwise require extensive peripheral gear. Best of all, SoundPals “systems” can be re-configured quickly and easily — to suit your changing audio production requirements.

All SoundPals modules are extremely compact, rugged, and identical in size for ease of installation, interconnection, and use. In addition, SoundPals support AES3id. This allows longer, more robust AES signal distribution using standard coaxial cable. Error free distances of 1000 feet can be attained using inexpensive coaxial cables.

Documentation Conventions

The following documentation conventions are used in this guide:

- Buttons, knobs, connectors, and switches are indicated in bold-faced capital letters. For example:

Adjust the left **GAIN TRIM** to ...

- Primary sections are listed in bold text, with a line above:

Primary Section

- Secondary sections are listed in bold text, with no line:

Secondary Section

Signals and Values

Note the following important information regarding audio signal level:

- AES3 = Balanced output with 2 channels of digital audio (left and right)
- AES3id = Unbalanced output with 2 channels of digital audio (left and right)

Warnings

Please observe the following important warnings:

- Heed all warnings on the unit and in the instructions.
- Do not use this product in or near water.
- Route power cords and other cables so that they are not likely to be damaged. Disconnect power before cleaning. Do not use liquid or aerosol cleaners; use only a damp cloth.

Unpacking and Inspection

When you receive your SoundPals modules, inspect the cartons for signs of damage. Contact your dealer and the shipper *immediately* if you suspect any damage has occurred during shipping. Check the contents of each box to be sure that all parts are included. If any items are missing, contact your dealer immediately.

Power Supply Note

SoundPals are delivered with a power connector *only*. A separate power supply must be obtained. Graham-Patten offers several power solutions for both domestic and international customers. Refer to “**External Power**” for detailed power specifications for users who wish to configure their own power source, rather than purchase one from Graham-Patten.

ADLY-4/B

About the ADLY-4/B

The SoundPals ADLY-4/B is an 8 channel (4 AES pairs) audio delay solution which ties the audio delay to video frame delay values. The ADLY-4/B delays all 8 channels up to 99.9 video frames at 24, 25 or 30 frames per second and is adjustable in 0.1 frame steps using three decade switches. It also has a reference switch selectable to either the external AES3id loop-thru reference BNC's or the AES channel 1 Input. There are four valid AES input led's as well as a valid reference led. The unit will accept any sample rate between 32kHz and 50kHz.

The unit offers the following features:

- Four AES3id (8 channels) unbalanced inputs
- Four AES3id (8 channels) unbalanced outputs
- 10-position rotary 0.1 frame delay switch
- 10-position rotary 1.0 frame delay switch
- 10-position rotary 10.0 frame delay switch
- Frame rate selection switch
- External AES3id reference loop thru BNC's
- Valid AES indicator led's (4 each)
- Valid reference led.
- Data Resolution: 24 Bits
- All Channel Status and User Bits pass through at same delay as audio
- Optional rack mounting tray (1 RU)
- Optional rack mounted (1RU) XLR Input/Output Panel (8 AES pairs each)
- Compact size, rugged construction

Note that the ADLY-4/B can synchronize to any sample rate between 32kHz to 50kHz but is only video frame accurate at 48kHz.

The figure below illustrates the ADLY-4/B's front panel:

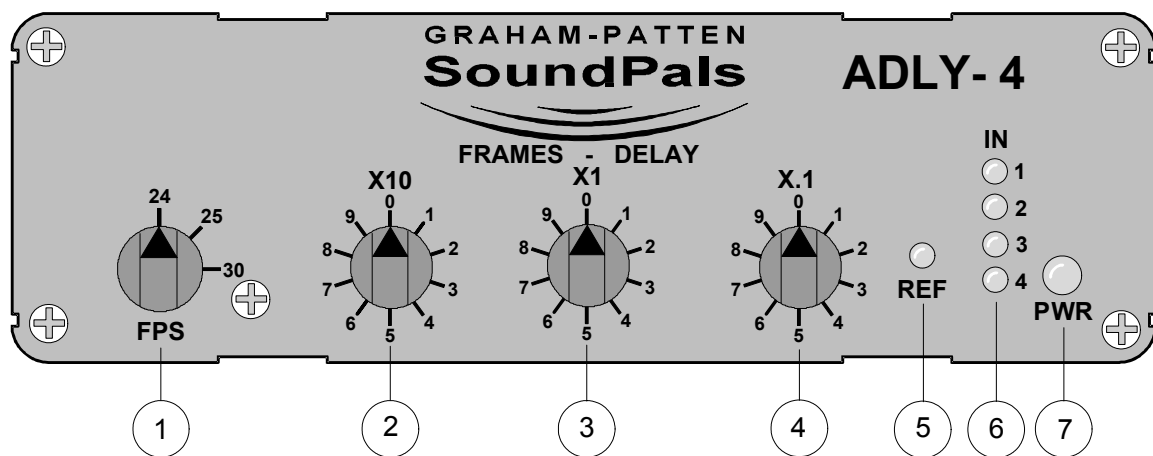

- 1) **Video Frame Rate Switch** — selects the video frame rate in frames per second.
- 2) **X10 Frame Delay Switch** — the 10-position rotary **X10 Frame Delay Switch** allows you to select frame delay in multiples of 10 frames per step. (Note: frame rate is only accurate at 48kHz sample rate.)

- 3) **X1 Frame Delay Switch** — the 10-position rotary **X1 Frame Delay Switch** allows you to select frame delay in multiples of 1 frame per step. (Note: frame rate is only accurate at 48kHz sample rate.)
- 4) **X.1 Frame Delay Switch** — the 10-position rotary **X.1 Frame Delay Switch** allows you to select frame delay in multiples of 0.1 (10th of a frame) frames per step. (Note: frame rate is only accurate at 48kHz sample rate.)
- 5) **Reference LED** — when lit this green led indicates a valid AES reference either using the external reference BNC's or AES input channel 1 depending on the selection of the **Reference Switch** on the rear of the unit.
- 6) **Valid AES Input led's** — these four green led's indicate you have a valid AES input for the led that is illuminated.
- 7) **PWR** — the green **Power LED** lights when power is applied.

The figure below illustrates the ADLY-4/B's rear panel:

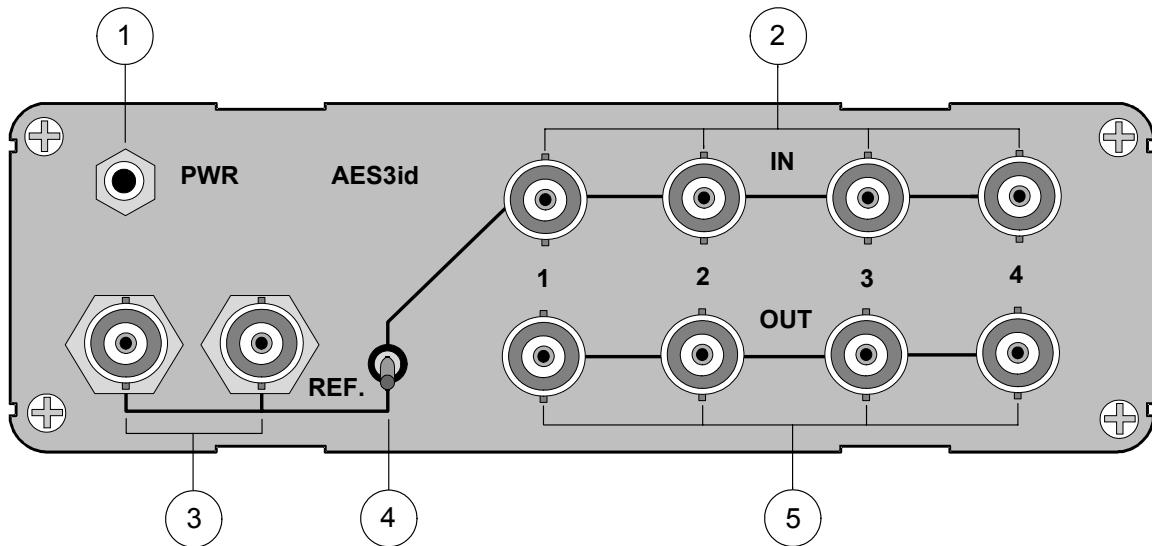

- 1) **Power Connector** — accepts the power jack from the 6VDC supply. Refer to “**External Power**” for more information on external power.
- 2) **AES3id Unbalanced Inputs** — provides 4 AES3id unbalanced channel inputs via a BNC connector for each AES3id input channel.
- 3) **External Reference AES3id Loop Thru BNC's** — provides a BNC external input AES3id reference signal input, which can be looped thru, when the **Reference Selection Switch** is in the down position. Note that when not using these BNC's as a loop-thru the open BNC should be terminated with 75 Ohms.*
- 4) **Reference Selection Switch** — in the down position selects the AES reference from the External AES3id Reference BNC's. In the up position selects AES3id input channel 1 as the reference.*
- 5) **AES3id Unbalanced Outputs** — provides 4 AES3id unbalanced channel outputs via BNC connectors, one for each AES3id output channel.

* The AES reference signal, either external or AES channel 1, must have a sampling frequency between 30kHz and 50kHz.

Installation

This section provides instructions for connecting power, the reference input, and the AES3id waveform inputs and outputs.

Connecting Power

Plug a 6VDC power supply (rated at **150 mA** or greater) into the appropriate voltage outlet for *your specific country*, and connect the end of the cord into the jack marked **PWR**. Secure the locking ring finger tight. The green **PWR** LED lights when power is applied.

Connecting Reference Input

The ADLY-4/B can be synchronized to an external AES3id signal waveform or can be set to synchronize to the AES channel 1 input based on the position of the **Reference Selection Switch**.

With the **Reference Selection Switch** in the down position the internal sample rate is locked to and set by the AES3id signal present on the **External Reference AES3id loop-thru BNC's**. These BNC inputs accept any valid AES3id 75 ohm signal with a sample rate between 30kHz and 50kHz and a voltage level between 400 mV and 1 volt peak-peak. Either BNC can be used as input/output. When a valid AES3id signal is present on the BNC's and the **Reference Selection Switch** is in the down position, the green **Reference LED** will light on the front of the unit. If the External Reference BNC's are not to be used as a loop-thru the remaining BNC should be terminated with 75 ohms. Note that when it is necessary to loop the reference to several SoundPals, the signal must be terminated only once, and always at the last unit in the chain.

With the **Reference Selection Switch** in the up position the internal sample rate is locked to and set by the AES3id signal present on the AES3id Channel 1 input. This input will accept any valid unbalanced AES3id 75 ohm signal with a sample rate between 30-50kHz and a voltage level between with 400 mV and 1 volt peak-peak. When a valid AES3id signal is present on input channel 1's BNC connector and the **Reference Selection Switch** is in the up position the green **Reference LED** will light on the front of the unit. See "Connecting the AES3id waveform inputs" for information on wiring this input.

Connecting the AES Waveform Inputs

There are four AES3id input channel pairs (8 channels of audio) available on the rear of the unit via four BNC connectors. Cabling for the unbalanced inputs is **Center pin of BNC is the signal and outer shell of the BNC is ground**. Note all four AES3id inputs must be frequency locked at the same sample rate.

Connecting the AES Waveform Outputs

There are four AES3id output channel pairs (8 channels of audio) available on the rear of the unit via BNC connectors. Cabling for the unbalanced outputs is **Center pin of BNC is the signal and outer shell of the BNC is ground**. All four AES3id outputs will be locked to the selected reference and will be delayed by the same amount set by the three rotary frame delay switches.

Operation

This section provides explanations of the rotary frame delay and Ref switches on the front panel of the ADLY-4/B.

Using the Video Frame Rate Switch

The 3-position **Video Frame Rate Switch** allows a selection of the delay based on frame rates of 24, 25 and 30 frames per second. Select the frame rate of the video to be delayed by rotating the switch. It should be noted that the video frame rates are only accurate at a 48kHz sample rate reference. At other sample rates the delay time is 48Khz divided by the sample rate. As an example if the sample is 32kHz, the delay is $48\text{kHz}/32\text{kHz}$ or 1.5 times the selected delay.

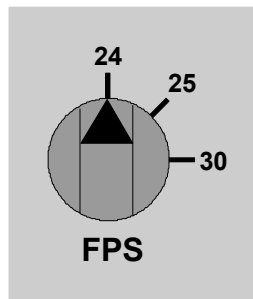

Frame Rate Switch

The table below provides a delay values in milli seconds for each **Frame Delay Switch** based on where the **Video Frame Rate Switch** is set. Note that these values are based on a 48kHz sample rate.

Position	10 Frames @ 48kHz	1 Frame @ 48kHz	0.1 Frames @ 48kHz
24	416.4 ms	41.6 ms	4.16 ms
25	400 ms	40 ms	4.0 ms
30	333.33 ms	33.33 ms	3.33 ms

Using the Frame Delay Switches

The three 10-position **Frame Delay Switches** are broken down to three separate values. These values are X10, X1 and X.1 and are labeled above the switch that they apply to. Dial in the delay in frames desired using the multiplier labeled above the switch. The illustration below shows a delay of 74.2 frames. The X10 switch is set to 7 which represents 70 frames, the X1 switch is set to 4 which represents 4 frames and the X.1 switch is set to 2 which represents .2 frames. Adding them together makes 74.2 frames of delay. At a 48kHz audio sample rate and 30 frames per second video setting this is a total delay of 2.47098 seconds. All four unbalanced AES3id outputs will be delayed by this value.

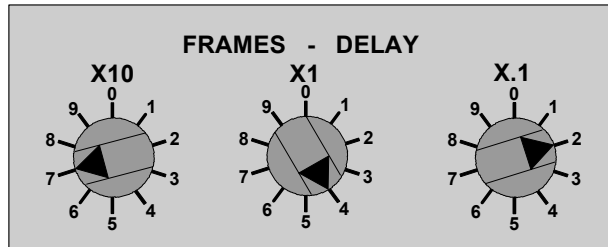

Using the Reference Selection Switch

The 2-position **Reference Selection Switch** allows for selection of the ADLY-4/B internal sample rate to lock to and be set by the Reference Input BNC's or AES3id Channel 1 input. With the switch set as shown, in the down position, the ADLY-4/B uses the AES3id signal present on the reference BNC's.

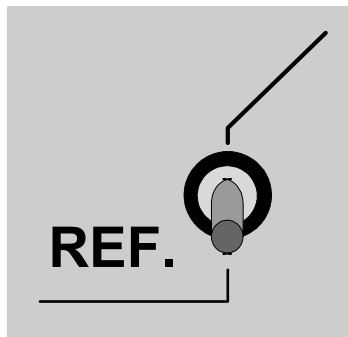

By placing the **Reference Selection Switch** in the up position the ADLY-4/B internal sample rate is locked to and set by the AES3id Channel 1 input present on the BNC connector labeled In 1.

Several things about the reference signal should be noted. First, there must have a valid AES3id signal present on either one of the BNC inputs or the AES3id Channel 1 input at a sampling frequency of between 30-50kHz. This can be verified by making sure the **Reference LED** is lit. Secondly, the Frame Delay values set by the **Frame Delay Switches** are only accurate at a 48kHz sample rate signal. Third, the AES3id reference signal used should be phase lock looped to the video using a VRG-1 (SoundPal Video Reference Generator) for accuracy.

Interconnection

This section provides a typical ADLY-4/B interconnection diagram.

- **De-embedding and Delaying Embedded Audio**

In this application, a house NTSC reference is connected to the VRG-1 SoundPal to create an AES3id reference signal that is locked to the house NTSC signal. This AES3id signal is then routed to the External Reference AES3id BNC input on the ALDY-4/U. Its loop-thru output is then terminated. The Reference Selection Switch is set to the down position to lock the ADLY-4/B to the external BNC AES3id inputs and the FPS is then set to 30 frames to be frame accurate to the NTSC signal. A synchronous SDI TV signal with the embedded audio to be delayed is then fed to an AEDM-4/SD SoundPal. This SoundPal de-embeds any two of the four channel groupings into 8 channels (four AES3id channel pairs) of synchronous audio. This audio is then fed to the ADLY-4/B SoundPal Delay module. The output of the ADLY-4/B Delay module then provides the 8 Channels (4 AES3id Channel Pairs) of audio delayed by the amount of frames set by the three Delay-Frame Switches and locked to the house NTSC reference.

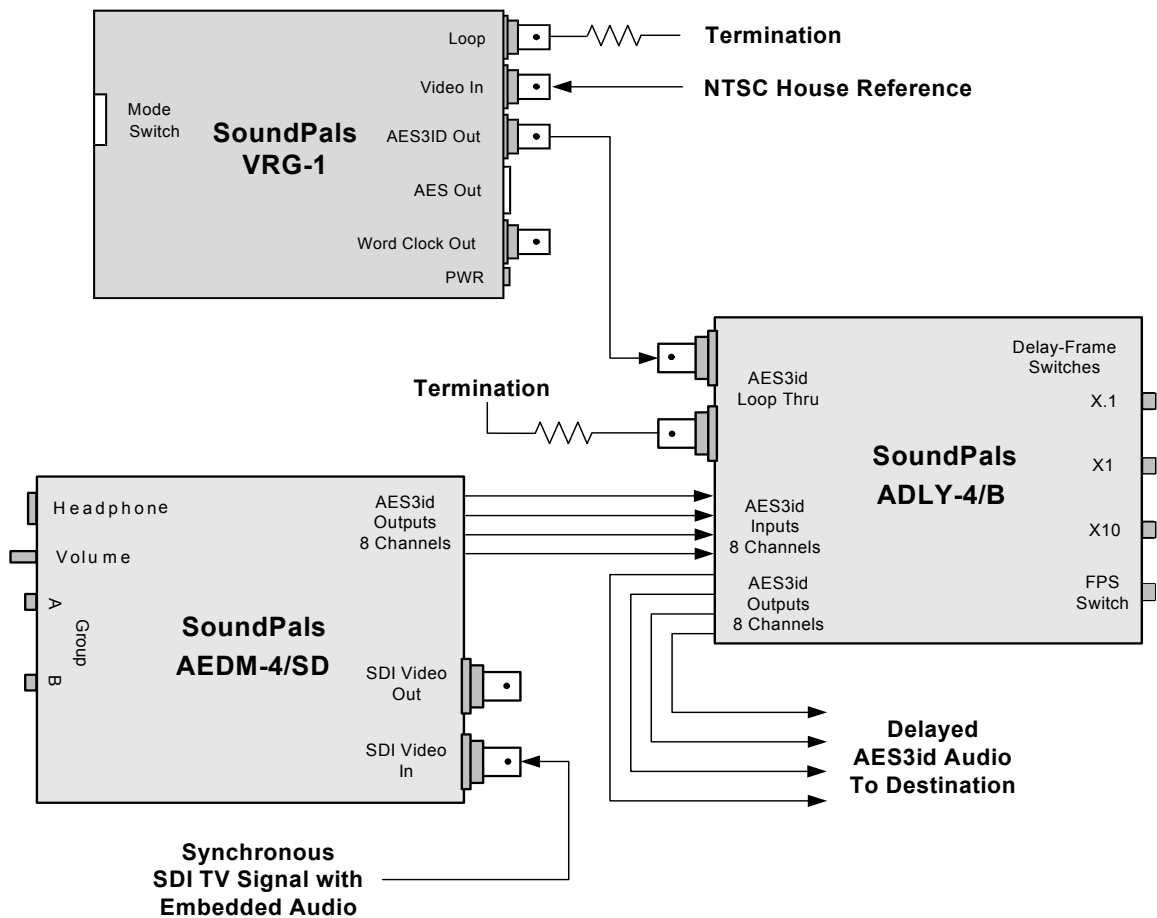

Note: It is possible in this setup to lock the ADLY-4/B to the Channel 1 input by placing the Reference Selection Switch to the up position, therefore eliminating the VRG-1. If the Channel 1 AES3id Data stream is consistent this will work just fine. If not for stability reasons, it is suggested that an external AES3id sync to insure the AES3id input receivers remained locked even with the loss of the AES3id data stream.

Troubleshooting

The table below lists several ADLY-4/B problems, and provides a variety of “checklist” procedures designed to solve them.

Problem	Procedure
Power LED does not light, no outputs.	<ul style="list-style-type: none">• Ensure wall supply is plugged in properly and power connection is tight, not loose.• Check voltage from wall power supply for minimum 6 volts DC. Measure voltage at the supply connector, when disconnected from the ADLY-4/B.
REF LED does not light with an AES3id input connected to the REF input BNC's.	<ul style="list-style-type: none">• Check that the Reference Select Switch is in the down position.• Ensure that the amplitude of the AES3id signal is between .4 and 1.2 volts p-p, when connected to the ADLY-4/B REF Input BNC's.• Ensure that sample rate of the reference input is not outside the 30-50kHz range.
REF LED does not light with an AES3id input connected to the Channel 1 Input.	<ul style="list-style-type: none">• Check that the Valid AES3id Input 1 LED is lit.• Check that the Reference Select Switch is in the up position.
Input Valid LED's won't light.	<ul style="list-style-type: none">• Ensure that the amplitude of the AES3id signal is between .4 and 1.2 volts p-p, when connected to the ADLY-4/B.• Ensure that sample rate of the input is not outside the 30-50kHz range.
Clicking sound in audio tones.	<ul style="list-style-type: none">• Check that the REF LED is on.• Check that the devices that are feeding the ADLY-4/B inputs are also locked to the same source as the ADLY-4/B reference.

NOTE Please contact the GPS factory if the problem still exists after completing the above procedures.

Specifications

This section provides ADLY-4/B audio and environmental specifications.

Audio Specifications

Parameter	Specification
AES3id Inputs	
Nominal amplitude	400 mV to 1.2 Volts Peak-Peak
Sample Rate	30-50kHz
Input impedance	75 Ω \pm 20% (0.1–6 MHz)
Input Word Length	Up to 24 bits
AES3id Outputs	
Nominal amplitude	900 mV to 1.1 Volts Peak-Peak
Sample Rate	30-50kHz
Rise time	15-30ns
Output impedance	75 Ω
Output Word Length	Up to 24 Bits (same as input word length)
Status Bits	All status bits are passed through unchanged
AES3id Reference Input	
Min. eye opening	165mV x 0.5UI (typical level 1 V p-p)
Input impedance	75 Ω
Sample frequency	30-50kHz
Internal Delay through Unit	
All Switches set to 0	166uS \pm 20 uS
Options	
RT-2, 1RU rack tray for mounting up to 3 units	
Power supplies:	
<ul style="list-style-type: none">PSU-1, 90-260V 50/60Hz in-line power supply with detachable IEC power cord	

NOTE All specifications listed above subject to change without notice.

Environmental Specifications and Dimensions

Parameter	Specification
Dimensions (less connectors)	5.2W x 1.62H x 6.625D 13.2 x 4.1 x 16.8 cm
Power	<150 mA @ 6Vdc
Operating Temp.	10 – 50 °C
Operating Humidity	10 – 90% RH non-condensing

Inside the Module

In This Section

There are no serviceable items inside the SoundPals ADLY-4/B module.

Before You Begin

Check the following items before opening the module and attempting to remove the internal circuit board:

- If required, remove the SoundPals module from the rack tray.
- Disconnect the power supply from the front of the product.
- Disconnect all input and output cables.
- Perform the remaining steps *only* in a static free environment. Make sure that *you and the product* are both grounded.

The following tools are required:

- #2 Philips screwdriver

Opening the Module

Use the following steps to open the ADLY-4/B module:

1. On the front panel, remove the four knobs from the Frame-Delay and FPS Switches.
2. On the front panel, remove the four Phillips screws from the four corners of the SoundPals module using the #2 Phillips screwdriver.
3. On the front panel, remove the one Phillips circuit board mounting screw.
4. On the rear panel, remove the four Phillips screws from the four corners of the SoundPals module using the #2 Phillips screwdriver.
5. Pulling the rear panel, carefully draw the internal circuit board and front panel assembly from the housing.
6. Set the housing and all mounting hardware in a safe place.

Closing The Module

Use the following steps to close a SoundPals module:

1. Ensure that the product label is on the bottom.
2. Carefully slide the internal circuit board and rear panel assembly through the housing.

3. Start all five screws on the front panel.
4. Tighten all four screws on the corners of the rear panel followed by tightening all four screws on the corners front panel.
5. Snug up the last screw next to the FPS switch on the front panel.

CAUTION Do not over tighten this screw.

7. Replace the four knobs removed earlier from the Frame-Delay and FPS Switches on the front panel.

External Power

About Power Supplies

An external power supply conforming to the specifications listed in the following “**Power Supply Specifications**” section *must be used* to guarantee that published SoundPals performance figures are met. Any power supply meeting these specifications will supply adequate power for a single SoundPals module. Although the specification is written for power supplies running from AC line inputs, DC (battery) sources may be used if they meet all of the listed requirements.

CE Compliance

For CE compliance, the power supply that you use *must comply* with the following requirements:

- Low Voltage Directive 73/23/EEC
- EMC Directive 89/336/EEC
- EMC Directive 93/68/EEC
- The connector locking ring must be tight.

Portable Power Sources

For portable SoundPals power sources, sealed lead-acid, nickel cadmium or alkaline primary batteries may be used. However, the maximum voltage must *not* exceed 8.6 volts, and a minimum of 5.6 volts is required for normal operation. Maximum current drain will be 161 mA.

Power Supply Specifications

The following specifications must be met over all anticipated operating conditions including AC power line range, temperature range, etc.

Parameter	Specification
Output voltage	5.6V minimum (measured at trough of ripple) at 161 mA constant current. 8.6V maximum (measured at peak of ripple) at 105 mA constant current.
Ripple voltage	2V p-p at 700mA constant current. 400mV p-p at 700mA constant current with external 2200 μ F capacitor.
Connector	Switchcraft 761K with center positive, sleeve negative.

Power Supply Sources

In addition to the GPS-supplied universal power supply, the following power supplies meet the SoundPals requirements:

Company	Model	Note
Stancor	STA-4860	120V AC, 60 Hz
Stancor	STAF-0797F	220V AC, 50 Hz with European wall plug (CE compliant).
Elpac	MI2007	95-250V AC, 47-63 Hz with IEC inlet (line cord required). Will power up to six units (CE compliant).