

ASDM-8 User Guide

HD/SD Auto Audio De-embedder



Printing History

SoundPals™ ASDM-8 User Guide

Rev. N/C

March 2007

Printed in U.S.A.

Part Number **08-2057-00**

The information contained in this guide is subject to change without notice or obligation.

Copyrights and Trademarks

© 2005 GRAHAM-PATTEN SYSTEMS, INC.

Contents of this publication may not be reproduced in any form without the written permission of Graham-Patten. Reproduction or reverse engineering of copyrighted software is prohibited.

FCC Compliance

This equipment has been tested and found to comply with the limits for a Class A digital device pursuant to Part 15 of the FCC Rules. These limits are designed to provide reasonable protection against harmful interference when the equipment is operated in a commercial environment. This equipment generates, uses, and can radiate radio frequency energy and, if not installed and used in accordance with the instruction manual, may cause harmful interference to radio communications. Operation of this equipment in a residential area is likely to cause harmful interference in which case the user will be required to correct the interference at your own expense.

Warranty Statement

Graham-Patten warrants that the equipment it manufactures is free from defects in workmanship and materials and meets applicable published specifications. Equipment that has been operated within published ratings and has not been subjected to abuse or modification, and which fails because of such defects, will be replaced or repaired at the Company's discretion if it is returned, freight prepaid, to Graham-Patten within seven years of receipt.

This warranty supersedes all other Warranties, express or implied. Graham-Patten is not liable for any consequential damages.

Company Address



GRAHAM-PATTEN SYSTEMS, INC.
119 East McKnight Way, Unit A
Grass Valley, California 95949
Telephone: (888) 622-4747, (530) 477-2984
Fax: (530) 477-2986
e-mail: info@isis-group.com
World Wide Web: www.gpsys.com

Graham-Patten is a division of



Table of Contents

Table of Contents	ii
Introduction	1
What are SoundPals?.....	1
Documentation Conventions.....	1
Signals and Values.....	1
Warnings.....	1
Unpacking and Inspection	2
Power Supply Note	2
ASDM-8	3
About the ASDM-8.....	3
ASDM-8 Installation	4
Connecting Power	4
Connecting the SDI / HDTV Input	4
Connecting SDI / HDTV Output	5
Connecting Analog Audio Outputs	5
Connecting Headphone Audio Output	5
ASDM-8 Operation	5
ASDM-8 Interconnection.....	6
HDTV-to-De-Embedded Analog Audio Monitoring	6
ASDM-8 Internal Analog Channel Level Adjustments	7
ASDM-8 Troubleshooting	7
ASDM-8 Specifications	8
Audio Specifications	8
Environmental Specifications and Dimensions	9
Inside the Module	9
In This Section	9
Before You Begin.....	9
Opening the Module	9
Closing the Module	9
External Power	10
About Power Supplies	10
CE Compliance	10
Portable Power Sources	10
Power Supply Specifications	10
Power Supply Sources	11

Introduction

What are SoundPals?

Each Graham-Patten SoundPals module is essentially a digital audio *building block* that can be used independently, or interconnected to perform more advanced mixing and audio processing functions.

SoundPals can be used in both standalone and system configurations:

- In a “standalone” configuration, each SoundPals module is designed to perform a specific audio processing function such as ADAT-to-Analog conversion. In this way, each module functions as a perfect low-cost adjunct to larger mixing consoles (such as the Graham-Patten D/ESAM series) — for single-purpose processing tasks.
- In a “system” configuration, SoundPals can be *linked* to form more comprehensive digital audio tools. For field recording, studio applications, and workstation applications, SoundPals can be used to seamlessly perform functions that would otherwise require extensive peripheral gear. Best of all, SoundPals “systems” can be re-configured quickly and easily — to suit your changing audio production requirements.

All SoundPals modules are extremely compact, rugged, and identical in size for ease of installation, interconnection, and use. In addition, SoundPals support AES3id. This allows longer, more robust AES signal distribution using standard coaxial cable. Error free distances of 1000 feet can be attained using inexpensive coaxial cables.

Documentation Conventions

The following documentation conventions are used in this guide:

- Buttons, knobs, connectors, and switches are indicated in bold-faced capital letters. For example:

Adjust the left **GAIN TRIM** to ...

- Primary sections are listed in bold text, with a line above:

Primary Section

- Secondary sections are listed in bold text, with no line:

Secondary Section

Signals and Values

Note the following important information regarding audio signal level:

- 0dBu = 0.778Vrms

Warnings

Please observe the following important warnings:

- Heed all warnings on the unit and in the instructions.
- Do not use this product in or near water.
- Route power cords and other cables so that they are not likely to be damaged. Disconnect power before cleaning. Do not use liquid or aerosol cleaners; use only a damp cloth.

Unpacking and Inspection

When you receive your SoundPals modules, inspect the cartons for signs of damage. Contact your dealer and the shipper *immediately* if you suspect any damage has occurred during shipping. Check the contents of each box to be sure that all parts are included. If any items are missing, contact your dealer immediately.

Power Supply Note

SoundPals are delivered with a power connector *only*. A separate power supply must be obtained. Graham-Patten offers several power solutions for both domestic and international customers. Refer to “**External Power**” for detailed power specifications for users who wish to configure their own power source, rather than purchase one from Graham-Patten.

ASDM-8

About the ASDM-8

The SoundPals ASDM-8 is an SDI / HDTV audio de-embedder that separates any two 4-channel groupings in the SDI / HDTV embedded data stream into eight channels of analog audio. It also has a selectable headphone output with separate volume control to monitor any one of the stereo pairs selected in the A and B groupings. The ASDM-8 provides an equalized cable input as well as an active looping output for the SDI / HDTV data stream.

The unit offers the following features:

- Active looping high definition Input/Output.
- Eight analog -1dB to +4dB line-level outputs (at -20dBFS).
- Selectable 2-channel headphone output with independent volume control.
- A and B Group Switch Knobs.
- Optional rack mounting tray (1RU)
- Compact size, rugged construction

The figure below illustrates the ASDM-8 front panel:

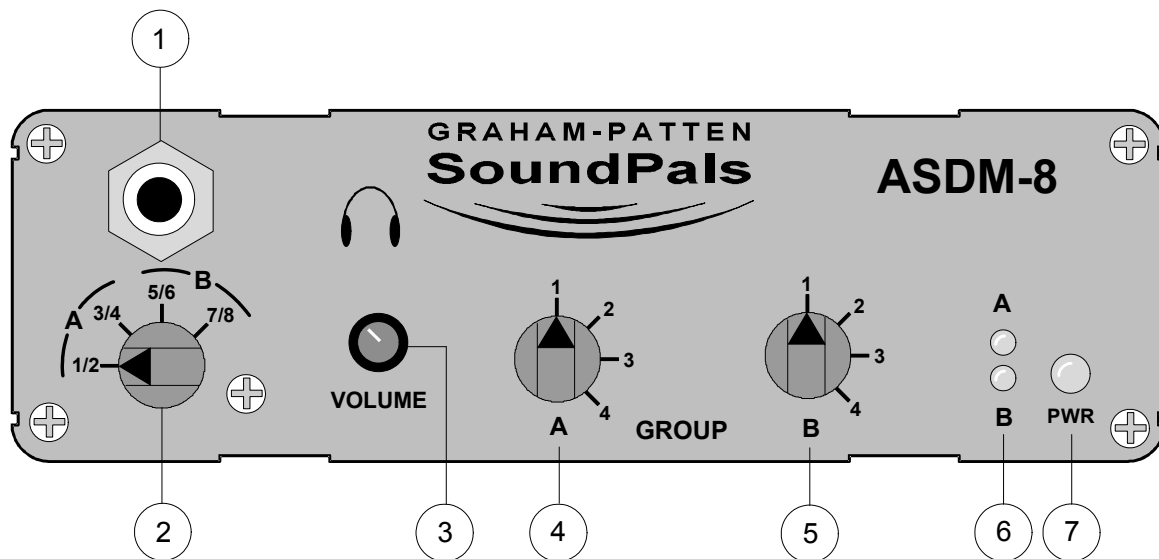

- 1) **1/4" Headphone Output** — Connects to any set of 1/4-inch TRS headphones.
- 2) **Headphone Channel Selection Switch** — Selects any stereo pair out of the selected A and B channel groupings. Channels 1-4 are always on the A grouping while channels 5-8 are always on the B Grouping.
- 3) **Headphone Volume Knob** — Adjusts the headphone volume output from dunk to -12 dB (at -20 dBFS).
- 4) **A Group Switch** — Selects any one of four embedded 4-channel groupings to analog outputs 1-4.

- 5) **B Group Switch** — Selects any one of four embedded 4-channel groupings to analog outputs 5-8.
- 6) **Group Indicators** — The A and B green LEDs on the front light when the selected group is receiving a valid signal, flickers for signal present but wrong format, and mutes if off.
- 7) **Power LED** — The large green LED lights when system power is applied.

The figure below illustrates the ASDM-8 rear panel:

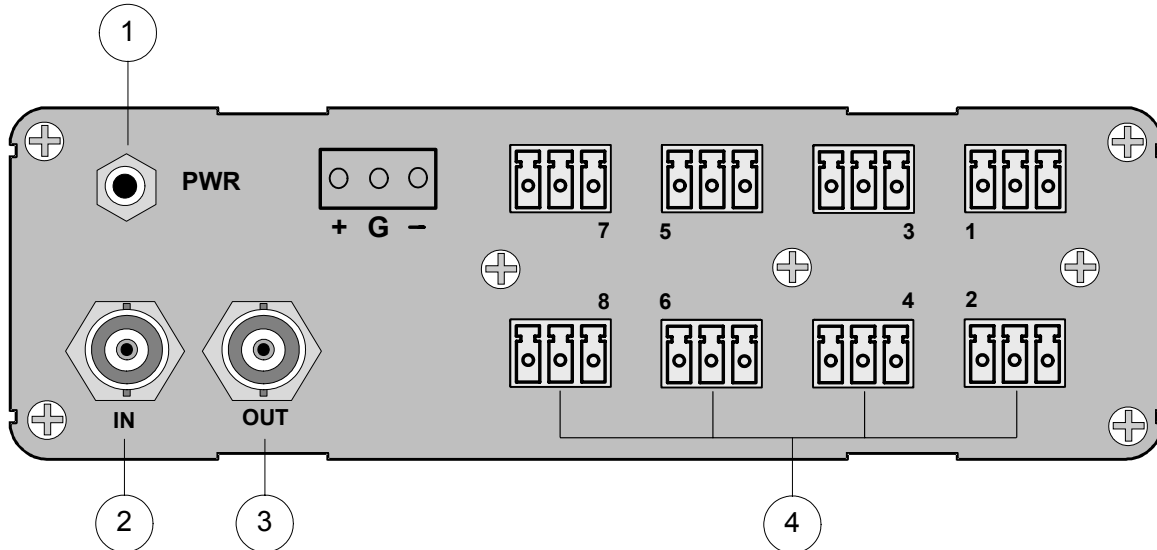

- 1) **Power Connector** — accepts the power jack from the 6VDC power supply. Refer to “**External Power**” section for more information regarding external power.
- 2) **SDI / HDTV BNC Input** — Accepts SDI or HDTV Serial Digital Input.
- 3) **SDI / HDTV BNC Output** — Active SDI or HDTV Serial Digital output. (One meter or less cable length)
- 4) **Analog Output Connectors** — Eight analog Phoenix output connectors. Outputs 1-4 are dedicated to Group A and outputs 5-8 are dedicated to Group B.

ASDM-8 Installation

This section provides instructions for connecting power, SDI / HDTV Digital Serial Input and Outputs as well as the audio balanced or unbalanced outputs.

Connecting Power

Plug a 6VDC power supply (rated at **1.1 Amps** or greater) into the appropriate voltage outlet for *your specific country*, and connect the end of the cord into the ASDM-8 jack marked **PWR**. Secure the locking ring finger tight. The green **PWR** LED lights when power is applied.

Connecting the SDI / HDTV Input

Connect the SDI Serial Digital Signal at 270 MB at either NTSC or PAL or the HDTV Serial Digital Signal at either 1.485 GB or 1.485/1.001 to the BNC marked **IN** on the rear of the unit. Check the A and B Group indicator LED's for a steady on condition which indicates a valid SDI / HDTV signal has been applied.

Connecting SDI / HDTV Output

Connect a BNC cable between the BNC on the rear panel marked **OUT** to another ASDM-8 or your video monitoring device. This output provides a regenerated copy of the SDI / HDTV Digital Serial Signal placed on the **IN** BNC connector. Using cable length of more than one meter may degrade the SDI / HDTV signal.

Connecting Analog Audio Outputs

There are eight independent analog audio Phoenix connectors on the rear of the unit marked **1-8**. The audio on the Phoenix connectors marked **1-4** will be de-embedded using the **A Group** switch. Audio on the Phoenix connectors **5-8** will be de-embedded using the **B Group** switch. Cabling for professional balanced outputs looking from left to right as you view the unit from the rear is **+ to Pin 1, Ground to Pin 2 and – to Pin 3** and is clearly marked on the unit. For Consumer level unbalanced outputs, again looking from left to right as you view the rear panel **+ to Pin 1 and Ground to PIN 2**. No connection is made to the **– Pin 3**. Eight male Phoenix connectors are provided with the unit for easy wiring.

Connecting Headphone Audio Output

The **Headphone** output is a ¼ inch **Tip/Ring/Sleeve** output. Wire the **Left Channel** to the **Tip**, **Right Channel** to the **Ring** and **Shield** to the **Sleeve**. The **Headphone Volume Knob** is used to adjust volume level.

ASDM-8 Operation

This section includes instructions for operating the ASDM-8. See the “**ASDM-8 Specifications**” section for information concerning the audio outputs or video input and outputs.

To operate the ASDM-8:

1. With SDI / HDTV Video input connected, use either the **A GROUP** or **B GROUP** switches to select which set of the four channel groupings you want to de-embed. (The **A Group** will de-embed the audio to the audio outputs **1-4** while the **B Group** will de-embed the audio to the audio outputs **5-8**.)
2. Check the **A and B Group Indicator LED's**. If they are fully on, you are receiving a valid embedded signal. If they flicker you have a SDI / HDTV signal applied that the ASDM-8 does not support applied. If the LED's are completely out, you have an invalid input signal applied to the unit and the audio outputs will be muted or the selected groups are not present. (Remember that the unit accepts 270 MB, 1.485 Gb or 1.485/1.001)
3. Once you have the **Group Indicator LED's** fully lit, you will be de-embedding the audio present in the selected grouping on the proper outputs. (**1-4 Group A, 5-8 Group B**) You can listen to those audio outputs using your **Headphones**, selecting the stereo pair wanted from the **Headphone Channel Selection Switch**, while adjusting the volume using the **Headphone Volume Knob**. Remember that you can only listen to one stereo pair at a time of the two selected channel groupings.

ASDM-8 Interconnection

This section provides an ASDM-8 interconnection diagram.

SDI / HDTV-to-De-Embedded Analog Audio Monitoring

There are many uses for SoundPals in music recording, radio or television broadcasting, DVD/CD/CR-ROM mastering, and video production and post-production.

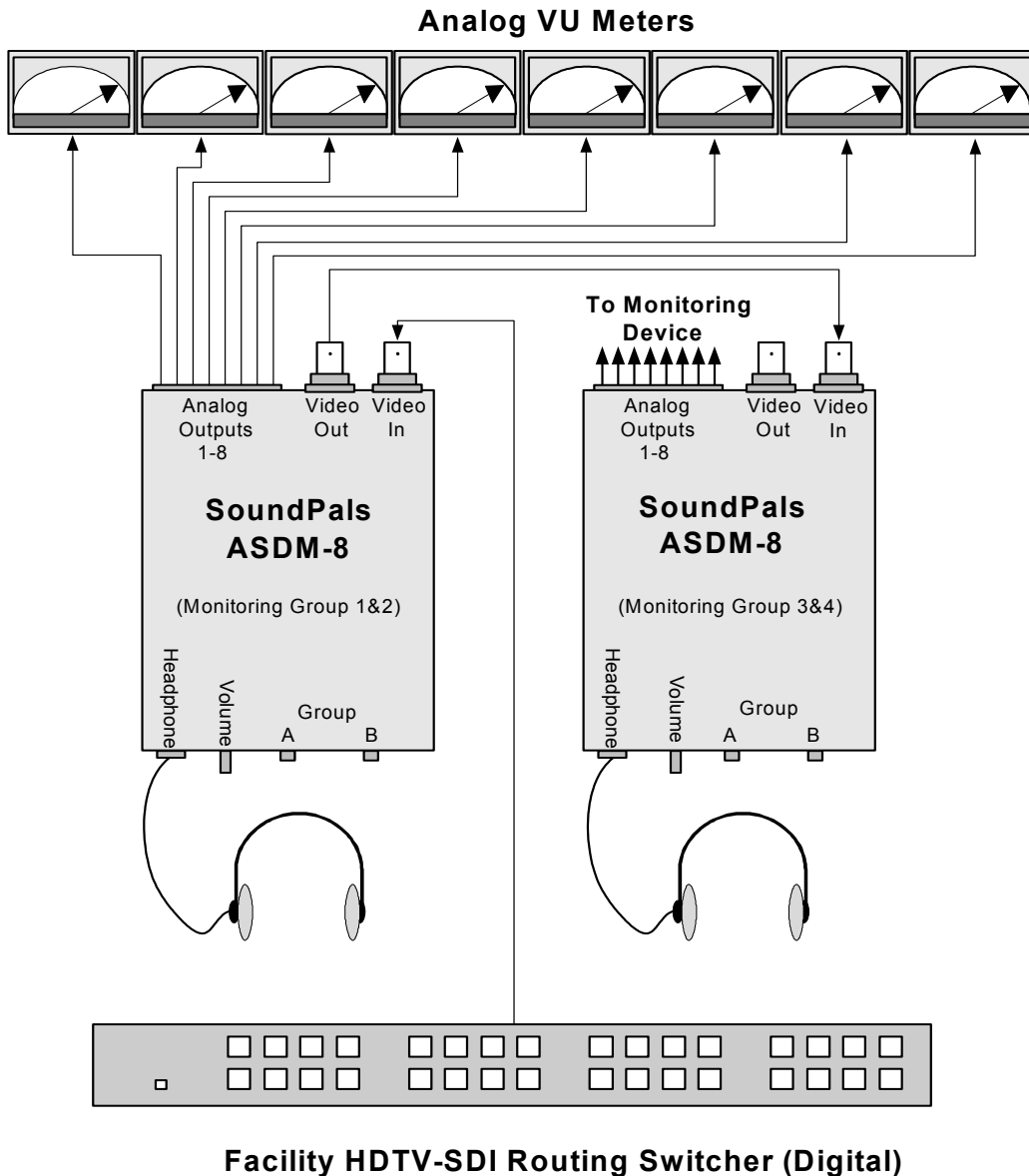

In this application, the facility's SDI / HDTV-SDI routing switcher is fed to the first ASDM-8 SoundPal, which is selected to monitor Group 1 & 2 and drive the eight Analog Meters. The video signal is then fed from the active video output connector to the second ASDM-8 SoundPal which is selected to monitor Group 3 & 4. The eight analog audio signals are then fed to a monitoring

device. Both ASDM-8 SoundPals have a set of headphones connected to them, making it easy for the operator to monitor any stereo pair of the four groups.

ASDM-8 Internal Analog Channel Level Adjustments

This section provides information about adjusting ASDM-8 analog output levels.

NOTE For detailed instructions on opening and closing the ASDM-8, see “Inside the Module.”

The figure below shows the ASDM-8 internal analog channel level adjustment locations:

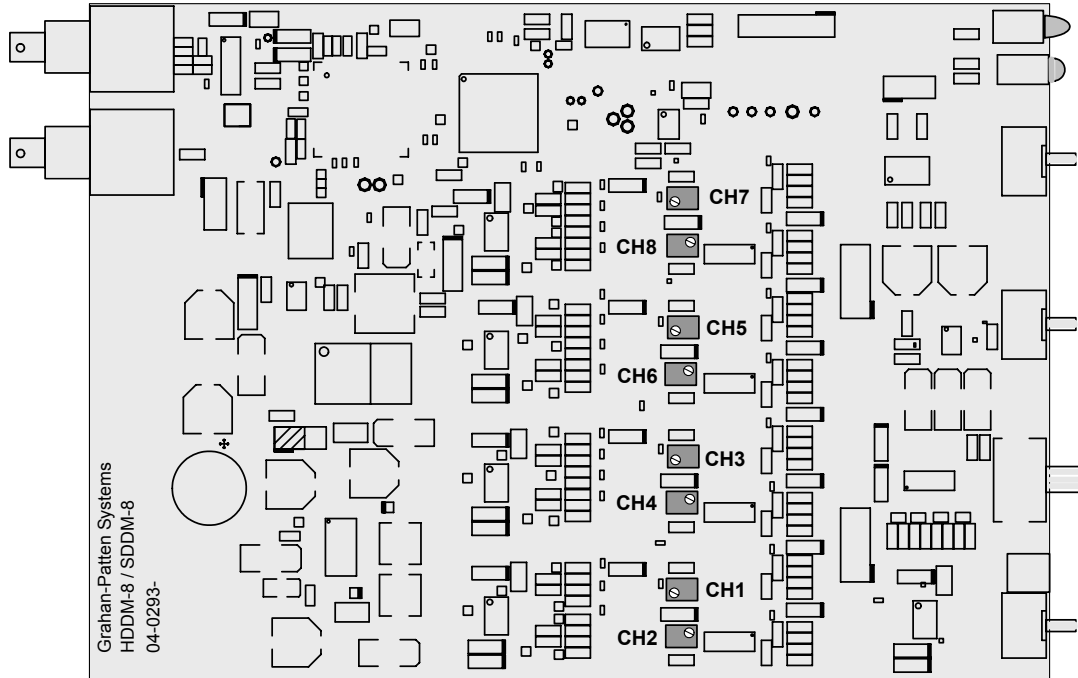

The ASDM-8 has individual internal potentiometers for adjusting the output levels. Above is a location diagram with highlighted potentiometers and channel number legends to aid you in adjusting your ASDM-8. From the factory your output levels are adjusted for +4 dBU with a -20 dBFS signal applied. The output levels can be adjusted from -1 dBU to a little above +4 dBU, again with -20 dBFS applied. Use caution when trying to adjust above +4 dBU with -20dBFS applied; if the input signal goes to 0 dBFS the analog input will go into clipping.

ASDM-8 Troubleshooting

The table below lists ASDM-8 problems and solutions.

Problem	Procedure
No output.	<ul style="list-style-type: none"> • Check Power by Green LED. • Check SDI / HDTV Digital Serial input BNC is connected properly. • Check A and B Group indicators for fully on condition.
Outputs are all silent.	<ul style="list-style-type: none"> • Check A and B Group indicators for fully on condition. • Check to see you have the proper Group selected with the A and B Group Switches.

NOTE Please contact the GPS factory if the problem still exists after completing the above procedures.

ASDM-8 Specifications

This section provides audio, remote, and environmental specifications, plus a table of ASDM-8 channel routing.

Audio Specifications

ASDM-8 Specifications	
Video Input	
Video with embedded audio	SMPTE 259M, 292M
Impedance	75Ω
Amplitude	800 mV ± 10% (terminated)
Equalization	0-100m Belden 8281 or Equivalent
Data Rate	270 MB, 1.485 Gbps or 1.485/1.001 Gbps
Input Return Loss	<15 dB
Embedded format	SMPTE 272M, 299M
Video formats	NTSC, PAL ,1080i, 1080p, 720p, 1125/60, SMPTE 259M, 125M, 274M, 296M, 260M
Audio	Digital
Sample Rate	48 KHz Synchronous to Video
Resolution	24 bits before D to A conversion
Audio	Analog out
Impedance, balanced	30Ω
Impedance, unbalanced	15Ω
Level, balanced	+4 dBu at -20 dBFS Adj -1dBu to +5dBu
Level, unbalanced	-2 dBu at -20 dBFS. Adj -8dBu to -1dBu
Max output	+24 dBu, bridging load +22 dBm, 600Ω load
THD+N	-86 dB at max output
Dynamic range	>96 dB
Frequency response	+0, -0.2 dB 20Hz to 20KHz
Headphone out	
Min Load	20Ω
Dynamic range	>91 dB
Options	
RT-2, 1RU rack tray for mounting up to 3 units	
Power supplies:	
<ul style="list-style-type: none"> PSU-1, 90-260V 50/60Hz in-line power supply with detachable IEC power cord 	

NOTE All specifications listed above subject to change without notice.

Environmental Specifications and Dimensions

Parameter	Specification
Dimensions (less connectors)	5.2W x 1.62H x 6.625D 13.2 x 4.1 x 16.8 cm
Power	<1.1 Amp @ 6Vdc
Operating Temp	10 – 50 °C
Operating Humidity	10 – 90% RH non-condensing

Inside the Module

In This Section

This section provides instructions for opening and closing the SoundPals ASDM-8 module to gain access to the internal circuit board.

NOTE The internal circuit board should only be removed from the module if you want to adjust the analog audio levels.

Before You Begin

Check the following items before opening the module and attempting to remove the internal circuit board:

- If required, remove the SoundPals module from the rack tray.
- Disconnect the power supply from the front of the product.
- Disconnect all input and output cables.
- Perform the remaining steps *only* in a static free environment. Make sure that *you and the product* are both grounded.

The following tools are required:

- #2 Philips screwdriver

Opening the Module

Use the following steps to open the ASDM-8 module:

1. On the front panel, remove the three knobs for the Headphone Channel Selection Switch and Group A and B Select switches.
2. Remove all five screws on the front panel using the #2 Philips screwdriver.
3. Once the front cover is off reach inside and remove the headphone connector from J2. Place the front panel off to the side.
4. On the rear panel remove just the four screws around the outer portion of the housing.
5. Slide the board out of the housing. Set the housing and all mounting hardware in a safe place.

Closing the Module

Use the following steps to close a SoundPals module:

1. Carefully slide the internal circuit board and rear panel assembly through the housing.

2. Start the four screws removed earlier but do not tighten yet.
3. Take the front panel with the Headphone jack and plug the headphone connector to J2 making sure to line up pins 1 (Brown wire on headphone connector to thick white line on silkscreen of J2).
4. Start all five screws on the front panel.
5. Now tighten all four screws on the rear panel followed by tightening all five on the front panel.

CAUTION Do not over tighten the screws.

6. On the front panel replace the three knobs removed earlier.

External Power

About Power Supplies

An external power supply conforming to the specifications listed in the following “**Power Supply Specifications**” section *must be used* to guarantee that published SoundPals performance figures are met. Any power supply meeting these specifications will supply adequate power for a single SoundPals module. Although the specification is written for power supplies running from AC line inputs, DC (battery) sources may be used if they meet all of the listed requirements.

CE Compliance

For CE compliance, the power supply that you use *must comply* with the following requirements:

- Low Voltage Directive 73/23/EEC
- EMC Directive 89/336/EEC
- EMC Directive 93/68/EEC
- The connector locking ring must be tight.

Portable Power Sources

For portable SoundPals power sources, sealed lead-acid, nickel cadmium or alkaline primary batteries may be used. However, the maximum voltage must *not* exceed 8.6 volts, and a minimum of 5.6 volts is required for normal operation. Maximum current drain will be 1.1 Amps.

Power Supply Specifications

The following specifications must be met over all anticipated operating conditions including AC power line range, temperature range, etc.

Parameter	Specification
Output voltage	5.6V minimum (measured at trough of ripple) at 1.1 Amp constant current. 8.6V maximum (measured at peak of ripple) at 700 mA constant current.
Ripple voltage	2V p-p at 700 mA constant current. 400mV p-p at 700mA constant current with external 2200 μ F capacitor.
Connector	Switchcraft 761K with center positive, sleeve negative.

Power Supply Sources

In addition to the GPS-supplied universal power supply, the following power supplies meet the SoundPals requirements:

Company	Model	Note
Stancor	STA-4860	120V AC, 60 Hz
Stancor	STAF-0797F	220V AC, 50 Hz with European wall plug (CE compliant).
Elpac	MI2007	95-250V AC, 47-63 Hz with IEC inlet (line cord required). Will power up to six units (CE compliant).