Printing History

SoundPals™ DA-14 AES Distribution Amplifier

Rev. N/C

March 2007

Printed in U.S.A.

Part Number **08-2051-00**

The information contained in this guide is subject to change without notice or obligation.

Copyrights and Trademarks

© 2005 GRAHAM-PATTEN SYSTEMS, INC.

Contents of this publication may not be reproduced in any form without the written permission of Graham-Patten. Reproduction or reverse engineering of copyrighted software is prohibited.

FCC Compliance

This equipment has been tested and found to comply with the limits for a Class A digital device pursuant to Part 15 of the FCC Rules. These limits are designed to provide reasonable protection against harmful interference when the equipment is operated in a commercial environment. This equipment generates, uses, and can radiate radio frequency energy and, if not installed and used in accordance with the instruction manual, may cause harmful interference to radio communications. Operation of this equipment in a residential area is likely to cause harmful interference in which case the user will be required to correct the interference at your own expense.

Warranty Statement

Graham-Patten warrants that the equipment it manufactures is free from defects in workmanship and materials and meets applicable published specifications. Equipment that has been operated within published ratings and has not been subjected to abuse or modification, and which fails because of such defects, will be replaced or repaired at the Company's discretion if it is returned, freight prepaid, to Graham-Patten within seven years of receipt.

This warranty supersedes all other Warranties, express or implied. Graham-Patten is not liable for any consequential damages.

Company Address



GRAHAM-PATTEN SYSTEMS, INC.
119 East McKnight Way, Unit A
Grass Valley, California 95949
Telephone: (888) 622-4747, (530) 477-2984
Fax: (530) 477-2986
e-mail: info@isis-group.com
World Wide Web: www.gpsys.com

Graham-Patten is a division of



Table of Contents

Table of Contents	ii
Introduction	1
What are SoundPals?.....	1
Documentation Conventions.....	1
Signals and Values.....	1
Warnings.....	1
Unpacking and Inspection	2
Power Supply Note	2
DA-14	3
About the DA-14	3
DA-14 Installation	5
Connecting Power	5
Connecting Inputs	5
Connecting Outputs.....	5
DA-14 Operation and Application	6
DA-14 Interconnection	7
Basic Digital Distribution	7
Multiple Outputs	8
DA-14 Internal Jumpers.....	9
DA-14 Troubleshooting.....	9
DA-14 Specifications	10
Audio Specifications.....	10
Environmental Specifications and Dimensions	11
Inside the Module	11
In This Section	11
Before You Begin.....	11
Opening the Module	11
Closing the Module	12
External Power	12
About Power Supplies	12
CE Compliance	12
Portable Power Sources	12
Power Supply Specifications	12
Power Supply Sources	13

Introduction

What are SoundPals?

Each Graham-Patten SoundPals module is essentially a digital audio *building block* that can be used independently, or interconnected to perform more advanced mixing and audio processing functions.

SoundPals can be used in both standalone and system configurations:

- In a “standalone” configuration, each SoundPals module is designed to perform a specific audio processing function such as ADAT-to-Analog conversion. In this way, each module functions as a perfect low-cost adjunct to larger mixing consoles (such as the Graham-Patten D/ESAM series) — for single-purpose processing tasks.
- In a “system” configuration, SoundPals can be *linked* to form more comprehensive digital audio tools. For field recording, studio applications, and workstation applications, SoundPals can be used to seamlessly perform functions that would otherwise require extensive peripheral gear. Best of all, SoundPals “systems” can be re-configured quickly and easily — to suit your changing audio production requirements.

All SoundPals modules are extremely compact, rugged, and identical in size for ease of installation, interconnection, and use. In addition, SoundPals support AES3id. This allows longer, more robust AES signal distribution using standard coaxial cable. Error free distances of 1000 feet can be attained using inexpensive coaxial cables.

Documentation Conventions

The following documentation conventions are used in this guide:

- Buttons, knobs, connectors, and switches are indicated in bold-faced capital letters. For example:

Adjust the left **GAIN TRIM** to ...

- Primary sections are listed in bold text, with a line above:

Primary Section

- Secondary sections are listed in bold text, with no line:

Secondary Section

Signals and Values

Note the following important information regarding audio signal level:

- AES3 = Balanced output with 2 channels of digital audio (left and right)
- AES3id = Unbalanced output with 2 channels of digital audio (left and right)

Warnings

Please observe the following important warnings:

- Heed all warnings on the unit and in the instructions.
- Do not use this product in or near water.
- Route power cords and other cables so that they are not likely to be damaged. Disconnect power before cleaning. Do not use liquid or aerosol cleaners; use only a damp cloth.

Unpacking and Inspection

When you receive your SoundPals modules, inspect the cartons for signs of damage. Contact your dealer and the shipper *immediately* if you suspect any damage has occurred during shipping. Check the contents of each box to be sure that all parts are included. If any items are missing, contact your dealer immediately.

Power Supply Note

SoundPals are delivered with a power connector *only*. A separate power supply must be obtained. Graham-Patten offers several power solutions for both domestic and international customers. Refer to “**External Power**” for detailed power specifications for users who wish to configure their own power source, rather than purchase one from Graham-Patten.

DA-14

About the DA-14

The SoundPals DA-14 is a one-input, four-output “data regenerator” for distributing AES digital audio signals. Two versions of the DA-14 are available:

- **Model A**
The DA-14 Model A provides four balanced AES3 outputs on XLR connectors.
- **Model B**
The DA-14 Model B provides four unbalanced AES3id outputs on BNC connectors.

NOTE The printed legend on the rear panel indicates the DA-14 model.

Both models include one AES3 input (on an XLR connector) and one AES3ID input (on a BNC connector). Note that only one input can be used at a time.

The DA-14 offers the following features:

- Choice of balanced AES outputs (XLR) or unbalanced AES3id outputs (BNC).
- Terminating or bridging inputs
- Accepts (and regenerates) any AES or AES3id digital input signal between 30 KHz and 50 KHz sampling frequency.
- Power and Status LEDs
- Optional rack mounting tray (1 RU)
- Compact size, rugged construction

The figure below illustrates the DA-14’s front panel:

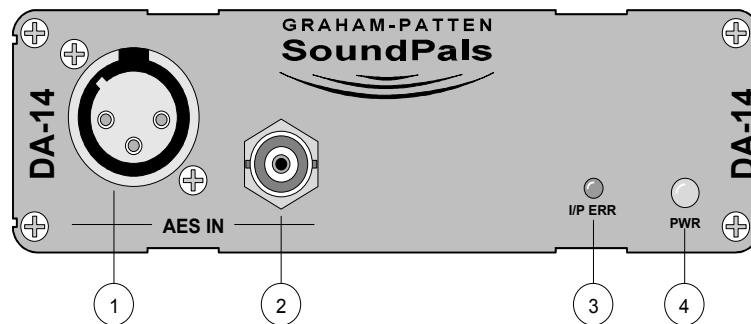

- 1) **AES Balanced Input** — the **AES IN** XLR connector accepts a balanced AES input signal.
- 2) **AES Unbalanced Input** — the **AES IN** BNC connector accepts an unbalanced AES input signal.

NOTE Do not connect both AES inputs at the same time.

- 3) **I/P ERR** — this LED lights when *no signal* is applied to the input, or when the signal is *not valid*. A non-valid signal exhibits errors such as format violations, bit errors, low level, or incorrect frequency. When **I/P ERR** is lit, output is muted.
- 4) **Power LED** — the green LED lights when power is applied.

The figure below illustrates the DA-14's rear panel.

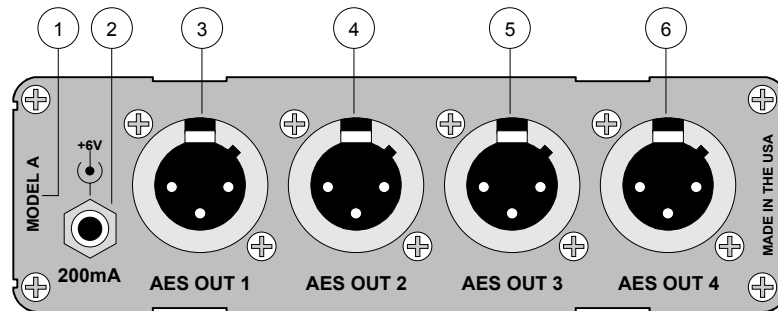

- 1) **DA-14 Model** — the printed legend indicates the model:
A (AES, balanced) or
B (AES3ID, unbalanced)

NOTE The Model A (with balanced XLRs) is shown above. The Model B provides unbalanced BNC connectors.

- 2) **Power Connector** — accepts the power jack from the 6VDC power supply. Refer to “**External Power**” for more information regarding external power.
- 3) **AES Output #1**
- 4) **AES Output #2**
- 5) **AES Output #3**
- 6) **AES Output #4**

DA-14 Installation

This section provides instructions for connecting power, digital inputs, and digital outputs.

Connecting Power

Plug a 6VDC power supply into the appropriate voltage outlet for *your specific country*, and connect the end of the cord into the DA-14 rear panel jack marked **+6V**. Secure the locking ring finger tight. The green LED on the front panel lights when power is applied.

Connecting Inputs

Connect a digital input signal, between 30 KHz and 50 KHz sampling frequency, to one of the two inputs marked **AES IN** on the front of the product. Both AES3 and AES3id inputs are provided.

NOTE Do not connect both AES inputs at the same time.

The inputs are normally terminated internally with 110 Ω (AES3) and 75 Ω (AES3id). When it is necessary to loop an input signal to several SoundPals, the signal must be terminated only once, and always at the last unit in the chain.

Refer to the “**DA-14 Internal Jumpers**” section for information on changing input termination.

NOTE The **I/P ERR** LED lights until a valid AES input signal is applied.

Connecting Outputs

Take the digital audio output from one of the four connectors marked **AES OUT**, and route it to the input of the desired destination device. Repeat the procedure for all digital outputs as required. Each output is *identical* in content to the input signal.

DA-14 Operation and Application

Because of the fundamental simplicity of the DA-14, there are no operating procedures apart from applying an input signal, connecting outputs, and applying power. There are no level adjustments, as the unit puts out a standard level. In addition, no reference is required as the DA-14 locks to the AES input signal.

In addition to basic distribution, two additional DA-14 applications should be noted:

- **S/PDIF to AES conversion**

Because the DA-14 can operate in a range as low as 165mv, it can be used as an S/PDIF to AES converter. By using an S/PDIF adapter on your S/PDIF source and connecting it to the DA-14's BNC input, you can achieve full level AES output (times four), provided that the source output is above the 165mv threshold. Note that S/PDIF adapters (BNC to RCA Phono) are readily available at consumer electronics stores.

- **Multiple output capability**

To configure two or more DA-14 units for multiple outputs (beyond the basic four), remove the terminating jumpers, place a BNC "T" on the input connector, and bridge as many DA-14s as required to produce the required number of outputs. In this configuration, ensure that the last DA-14 in the chain is terminated — either internally or externally with a 75 Ω terminator on the BNC "T" connector.

Refer to the following "**DA-14 Interconnection**" section for an illustration of this "multiple output" configuration. Refer to the "**DA-14 Internal Jumpers**" section for information on changing input termination.

DA-14 Interconnection

This section provides two basic DA-14 interconnection diagrams.

- **Basic Digital Distribution**

In this application, the DA-14's input is connected to an AES source (such as the ADC-24). The unit's four AES digital outputs are connected to AES destination devices in your facility. Note that *both* DA-14 models are shown.

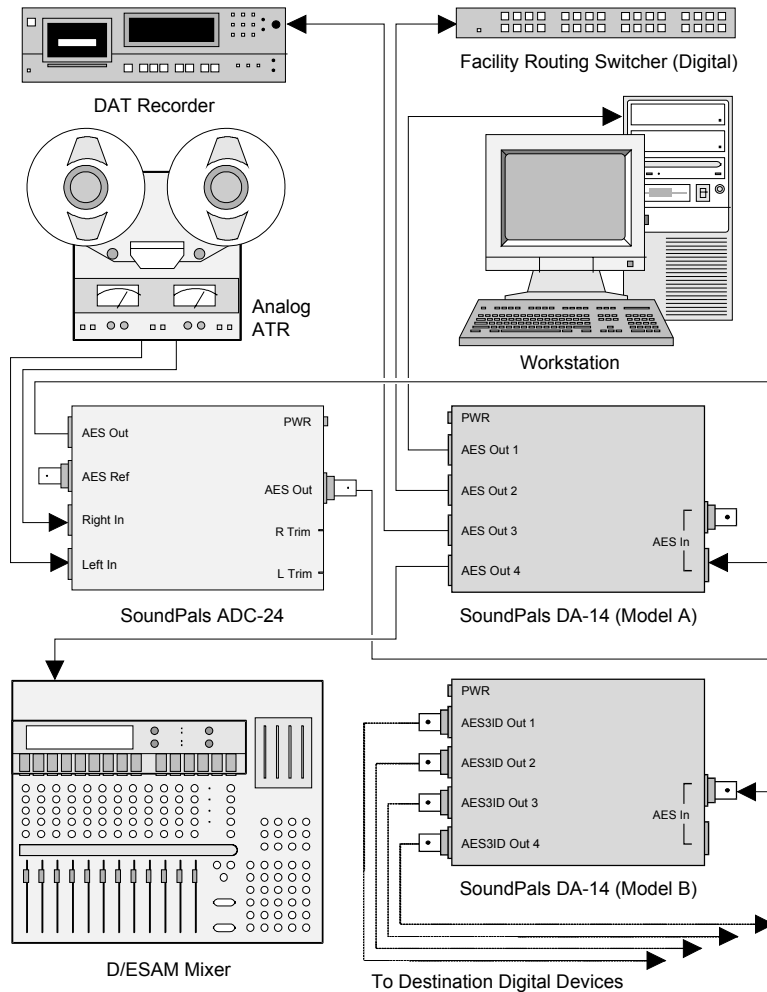

- **Multiple Outputs**

In this application, three DA-14 units are bridged together to produce 12 identical AES outputs. Note that the last DA-14 in the chain is terminated externally with a 75 Ω terminator.

NOTE All internal termination jumpers should be removed for this configuration. Refer to the “DA-14 Internal Jumpers” section for information.

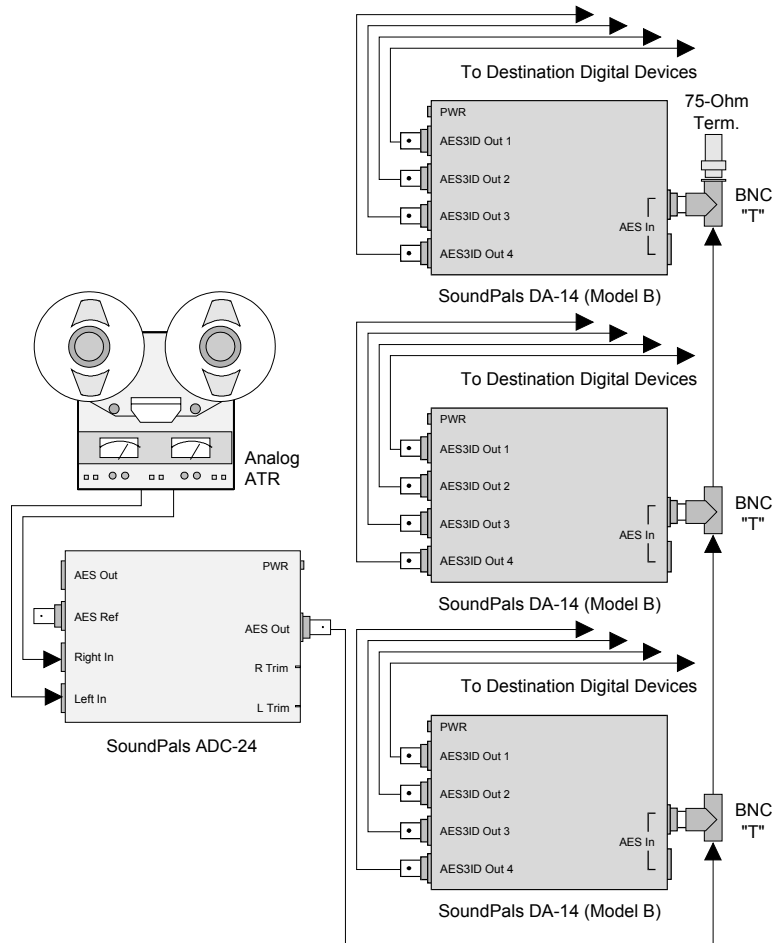

DA-14 Internal Jumpers

This section provides information about the DA-14's internal jumpers and adjustments.

NOTE For detailed instructions on opening and closing the DA-14, see “**Inside the Module.**”

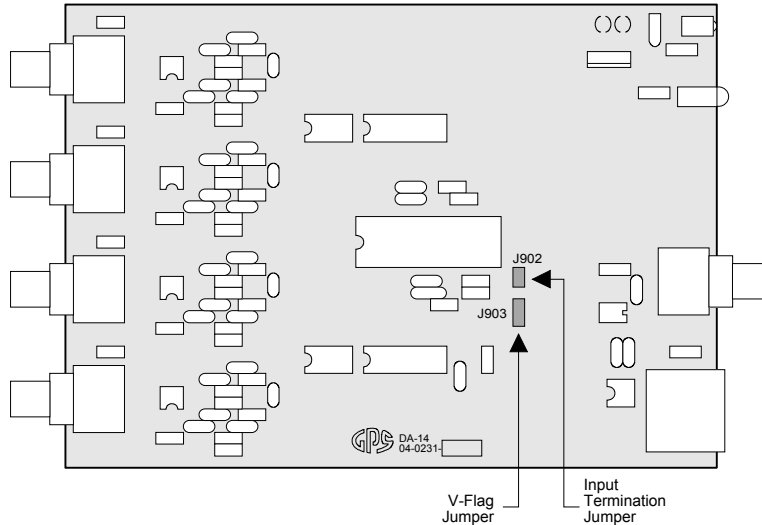

- To change the AES reference input from terminating to bridging, remove jumper **J902**.
- To change the **I/P ERR** LED such that it also detects the V-Flag (Validity Flag) in addition to invalid AES signals, place jumper **J903** between pins 2 and 3. When the jumper is between pins 1 and 2, the LED *only* indicates invalid AES signals (this is the default position).

DA-14 Troubleshooting

The table below lists several DA-14 problems, and provides a variety of “checklist” procedures designed to solve them.

Problem	Procedure
No signal at any AES or AES3id output.	<ul style="list-style-type: none"> • Is power applied? Check the power LED and power supply. • Is a valid AES input signal connected? Check I/P ERR LED off. • Is the input signal silent? Check the signal source. • Are the outputs correctly connected to the destination devices? • Is the sampling frequency within 4% of 48 KHz, 44.1 KHz, or 32 KHz?
No signal (or improper signal) at a “bridged” DA-14 unit.	<ul style="list-style-type: none"> • Are the DA-14 units properly bridged? • Are the terminating jumpers removed? • Is the last DA-14 unit in the chain properly terminated?

NOTE Please contact the GPS factory if the problem still exists after completing the above procedures.

DA-14 Specifications

This section provides environmental and audio specifications.

Audio Specifications

Specification	
Digital Inputs	
AES3	
Min. eye opening:	200 mV x 0.5 UI
Input impedance:	110 Ω or bridging
Sample frequency:	30-50 KHz
Maximum input:	7V p-p
AES3id	
Min. eye opening:	165 mV x 0.5 UI
Input impedance:	75 Ω or bridging
Return loss:	>15 dB (0.1-6 MHz)
Sample frequency:	30-50 KHz
Digital Outputs	
Model A (AES3)	Terminated in 110 Ω
Amplitude:	4.5V p-p
Rise time:	5-30 ns
Output impedance:	110 Ω \pm 20% (0.1-6 MHz)
Common mode:	<-30 dB (0-6 MHz)
Model B (AES3id)	Terminated in 75 Ω
Amplitude:	1.0V \pm 0.2V p-p
Rise time:	37 \pm 7 ns
Output impedance:	75 Ω
Return loss:	>15 dB (0.1-6 MHz)
DC on output	<50 mV
Data Jitter	
Peak jitter gain	0 dB
Jitter attenuation	>5 dB @ 100 KHz
	>70 dB @ 6 MHz
Options	
RT-2, 1RU rack tray for mounting up to 3 units	
Power supplies:	
<ul style="list-style-type: none"> PSU-1, 90-260V 50/60Hz in-line power supply with detachable IEC power cord 	

NOTE All specifications listed above subject to change without notice.

Environmental Specifications and Dimensions

Parameter	Specification
Dimensions (less connectors)	5.2W x 1.62H x 6.625D 13.2 x 4.1 x 16.8 cm
Power	375 mA @ 6Vdc
Operating Temp.	10 – 50 °C
Operating Humidity	10 – 90%RH non-condensing

Inside the Module

In This Section

This section provides instructions for opening and closing the SoundPals DA-14 module to gain access to the internal circuit board.

NOTE The internal circuit board should only be removed from the module if you want to reset the jumpers.

Before You Begin

Check the following items before opening the module and attempting to remove the internal circuit board:

- If required, remove the SoundPals module from the rack tray.
- Disconnect the power supply from the front of the product.
- Disconnect all input and output cables.
- Perform the remaining steps *only* in a static free environment. Make sure that *you and the product* are both grounded.

The following tools are required:

- #2 Philips screwdriver

Opening the Module

Use the following steps to open the DA-14 module:

1. On the rear panel, remove the four Phillips screws from the four corners of the SoundPals module.
2. On the front panel, remove all Philips XLR mounting screws from the module.
3. On the front panel (if BNC connectors are present), remove the BNC nut(s) and associated lock washer(s).
4. Pulling the rear panel, carefully draw the internal circuit board and rear panel assembly from the housing.

CAUTION If BNC connectors are present, keep the case horizontal so that the bushings stay with the connectors.

5. Set the housing and all mounting hardware in a safe place.

Closing the Module

Use the following steps to close the DA-14 module:

1. Ensure that product label is on the bottom.
2. Carefully slide the internal circuit board and rear panel assembly through the housing. If BNC connectors are present, keep the case horizontal so that the bushings stay with the connectors.
3. If required, replace all BNC nut(s) and associated lock washer(s) on the front panel of the module.
4. Replace all Philips XLR mounting screws on the front panel of the module.
5. Replace and tighten the four Phillips screws on the rear corners of the module.

CAUTION Do not over tighten the screws.

External Power

About Power Supplies

An external power supply conforming to the specifications listed in the following “**Power Supply Specifications**” section *must be used* to guarantee that published SoundPals performance figures are met. Any power supply meeting these specifications will supply adequate power for a single SoundPals module. Although the specification is written for power supplies running from AC line inputs, DC (battery) sources may be used if they meet all of the listed requirements.

CE Compliance

For CE compliance, the power supply that you use *must comply* with the following requirements:

- Low Voltage Directive 73/23/EEC
- EMC Directive 89/336/EEC
- EMC Directive 93/68/EEC
- The connector locking ring must be tight.

Portable Power Sources

For portable SoundPals power sources, sealed lead-acid, nickel cadmium or alkaline primary batteries may be used. However, the maximum voltage must *not* exceed 8.6 volts, and a minimum of 5.6 volts is required for normal operation. Maximum current drain will be 402 mA.

Power Supply Specifications

The following specifications must be met over all anticipated operating conditions including AC power line range, temperature range, etc.

Parameter	Specification
Output voltage	5.6V minimum (measured at trough of ripple) at 402 mA constant current. 8.6V maximum (measured at peak of ripple) at 262 mA constant current.
Ripple voltage	2V p-p at 700 mA constant current. 400mV p-p at 700mA constant current with external 2200 μ F capacitor.
Connector	Switchcraft 761K with center positive, sleeve negative.

Power Supply Sources

In addition to the GPS-supplied universal power supply, the following power supplies meet the SoundPals requirements:

Company	Model	Note
Stancor	STA-4860	120V AC, 60 Hz
Stancor	STAF-0797F	220V AC, 50 Hz with European wall plug (CE compliant).
Elpac	MI2007	95-250V AC, 47-63 Hz with IEC inlet (line cord required). Will power up to six units (CE compliant).