

DAC-24 User Guide

Stereo D-to-A converter



Printing History

SoundPals™ DAC-24 D-to-A converter

Rev. N/C

March 2007

Printed in U.S.A.

Part Number **08-2044-00**

The information contained in this guide is subject to change without notice or obligation.

Copyrights and Trademarks

© 2005 GRAHAM-PATTEN SYSTEMS, INC.

Contents of this publication may not be reproduced in any form without the written permission of Graham-Patten. Reproduction or reverse engineering of copyrighted software is prohibited.

FCC Compliance

This equipment has been tested and found to comply with the limits for a Class A digital device pursuant to Part 15 of the FCC Rules. These limits are designed to provide reasonable protection against harmful interference when the equipment is operated in a commercial environment. This equipment generates, uses, and can radiate radio frequency energy and, if not installed and used in accordance with the instruction manual, may cause harmful interference to radio communications. Operation of this equipment in a residential area is likely to cause harmful interference in which case the user will be required to correct the interference at your own expense.

Warranty Statement

Graham-Patten warrants that the equipment it manufactures is free from defects in workmanship and materials and meets applicable published specifications. Equipment that has been operated within published ratings and has not been subjected to abuse or modification, and which fails because of such defects, will be replaced or repaired at the Company's discretion if it is returned, freight prepaid, to Graham-Patten within seven years of receipt.

This warranty supersedes all other Warranties, express or implied. Graham-Patten is not liable for any consequential damages.

Company Address



GRAHAM-PATTEN SYSTEMS, INC.
119 East McKnight Way, Unit A
Grass Valley, California 95949
Telephone: (888) 622-4747, (530) 477-2984
Fax: (530) 477-2986
e-mail: info@isis-group.com
World Wide Web: www.gpsys.com

Graham-Patten is a division of



Table of Contents

Table of Contents	ii
Introduction	1
What are SoundPals?.....	1
Documentation Conventions.....	1
Signals and Values.....	1
Warnings.....	1
Unpacking and Inspection	2
Power Supply Note.....	2
DAC-24	3
About the DAC-24.....	3
DAC-24 Installation.....	4
Connecting Power.....	4
Connecting Input s.....	4
Connecting Output s.....	5
DAC-24 Operation	5
DAC-24 Interconnection	6
Basic - Monitoring Digital Signals.....	6
Basic - Inserting Analog Equipment.....	6
Advanced - Simultaneous Multi-Format Outputs	7
DAC-24 Internal Jumpers	8
DAC-24 Troubleshooting	8
DAC-24 Specifications.....	9
Audio Specifications.....	9
Environmental Specifications and Dimensions.....	9
Inside the Module	10
In This Section	10
Before You Begin.....	10
Opening the Module	10
Closing the Module.....	10
External Power	11
About Power Supplies	11
CE Compliance.....	11
Portable Power Sources.....	11
Power Supply Specifications	11
Power Supply Sources	11

Introduction

What are SoundPals?

Each Graham-Patten SoundPals module is essentially a digital audio *building block* that can be used independently, or interconnected to perform more advanced mixing and audio processing functions.

SoundPals can be used in both standalone and system configurations:

- In a “standalone” configuration, each SoundPals module is designed to perform a specific audio processing function such as ADAT-to-Analog conversion. In this way, each module functions as a perfect low-cost adjunct to larger mixing consoles (such as the Graham-Patten D/ESAM series) — for single-purpose processing tasks.
- In a “system” configuration, SoundPals can be *linked* to form more comprehensive digital audio tools. For field recording, studio applications, and workstation applications, SoundPals can be used to seamlessly perform functions that would otherwise require extensive peripheral gear. Best of all, SoundPals “systems” can be re-configured quickly and easily — to suit your changing audio production requirements.

All SoundPals modules are extremely compact, rugged, and identical in size for ease of installation, interconnection, and use. In addition, SoundPals support AES3id. This allows longer, more robust AES signal distribution using standard coaxial cable. Error free distances of 1000 feet can be attained using inexpensive coaxial cables.

Documentation Conventions

The following documentation conventions are used in this guide:

- Buttons, knobs, connectors, and switches are indicated in bold-faced capital letters. For example:

Adjust the left **GAIN TRIM** to ...

- Primary sections are listed in bold text, with a line above:

Primary Section

- Secondary sections are listed in bold text, with no line:

Secondary Section

Signals and Values

Note the following important information regarding audio signal level:

- 0dBu = 0.778Vrms
- AES3 = Balanced output with 2 channels of digital audio (left and right)
- AES3id = Unbalanced output with 2 channels of digital audio (left and right)

Warnings

Please observe the following important warnings:

- Heed all warnings on the unit and in the instructions.
- Do not use this product in or near water.
- Route power cords and other cables so that they are not likely to be damaged. Disconnect power before cleaning. Do not use liquid or aerosol cleaners; use only a damp cloth.

Unpacking and Inspection

When you receive your SoundPals modules, inspect the cartons for signs of damage. Contact your dealer and the shipper *immediately* if you suspect any damage has occurred during shipping. Check the contents of each box to be sure that all parts are included. If any items are missing, contact your dealer immediately.

Power Supply Note

SoundPals are delivered with a power connector *only*. A separate power supply must be obtained. Graham-Patten offers several power solutions for both domestic and international customers. Refer to “**External Power**” for detailed power specifications for users who wish to configure their own power source, rather than purchase one from Graham-Patten.

DAC-24

About the DAC-24

The SoundPals DAC-24 is a stereo, 24-bit, AES digital-to-analog converter. The unit offers the following features:

- Stereo headphone monitoring with level control
- 24-bit D/A converter
- Automatic detection and de-emphasis
- LED indicators for emphasis and valid AES input
- Separate analog output level adjustments (-10 to +4 dBu at -20 dBFS)
- Terminating or bridging input
- Optional rack mounting tray (1 RU)
- Compact size, rugged construction

The DAC-24 takes one AES input (on an XLR or BNC connector) and converts it to two analog outputs (on XLR connectors).

The figure below illustrates the DAC-24's front panel:

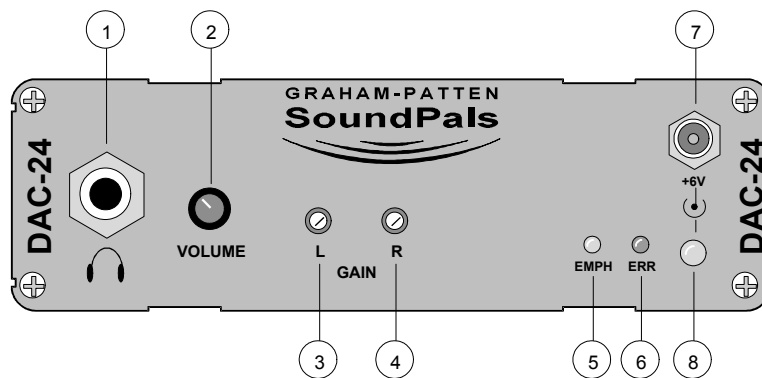

- 1) **Stereo Headphone Connector** — accepts standard low-impedance TRS stereo headphones.
- 2) **Headphone Gain Control** — adjusts stereo headphone volume. The control does not affect analog output levels.
- 3) **Left Analog Output Gain Trim** — the **L GAIN** trim sets the analog line level for the left channel output.
- 4) **Right Analog Output Gain Trim** — the **R GAIN** trim sets the analog line level for the right channel output.
- 5) **Emphasis Detection LED** — the **EMPH** LED lights when the channel status bits of the AES input signal indicates that pre-emphasis has been applied to the signal. If the sampling frequency is within 4% of 48 KHz, 44.1 KHz or 32 KHz, de-emphasis correction is automatically applied.
- 6) **AES Input Error LED** — the **ERR** LED lights when *no signal* is applied to the AES input, or when the signal is *not valid*. A non-valid signal exhibits errors such as format violations, bit errors, low level, or incorrect frequency.

- 7) **Power Connector** — accepts the power jack from the 6VDC power supply. Refer to “**External Power**” for more information regarding external power.
- 8) **Power LED** — the large green LED below the power jack lights when power is applied.

The figure below illustrates the DAC-24’s rear panel:

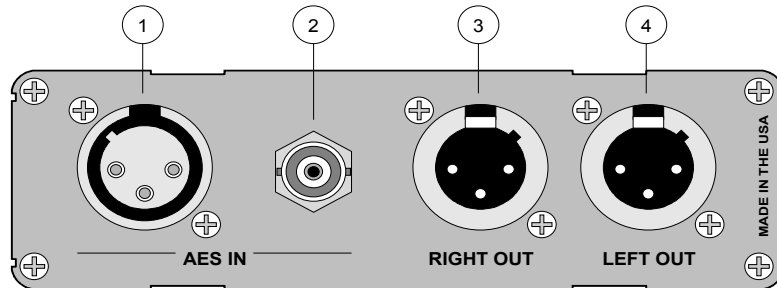

- 1) **AES Balanced Input** — the **AES IN** XLR connector accepts a balanced AES input signal.
- 2) **AES Unbalanced Input** — the **AES IN** BNC connector accepts an unbalanced AES input signal.
NOTE: Do not connect both AES inputs at the same time.
- 3) **Right Channel Analog Output** — provides decoded right channel output at analog line level, adjustable via **R GAIN** on the front panel.
- 4) **Left Channel Analog Output** — provides decoded left channel output at analog line level, adjustable via **L GAIN** on the front panel.

DAC-24 Installation

This section provides instructions for connecting power, AES inputs, and analog outputs.

Connecting Power

Plug a 6VDC power supply into the appropriate voltage outlet for *your specific country*, and connect the end of the cord into the DAC-24 jack marked **+6V**. Secure the locking ring finger tight. The green LED below the jack lights when power is applied.

Connecting Inputs

Connect a digital input signal, between 30 KHz and 50 KHz sampling frequency, to one of the two inputs marked **AES IN**. The **ERR** LED on the front panel will light until a valid input signal is applied.

NOTE Do not connect both AES inputs at the same time

The inputs are normally terminated internally with 110Ω (AES3) and 75Ω (AES3id). When you need to loop an input signal to several SoundPals, the signal must be terminated *only once*, and always at the last unit in the chain. Refer to the “**DAC-24 Internal Jumpers**” section for information on changing the input termination.

Connecting Outputs

Connect the analog audio outputs from the **LEFT OUT** and **RIGHT OUT** connectors to the inputs of the desired analog destination device. Please note:

- Balanced outputs are taken from pins 2 (+) and 3 (-) with pin 1 and the shell grounded.
- Unbalanced outputs are taken from pin 2 with pin 1 and the shell grounded.

CAUTION Do not connect pin 3 to the low (grounded) side of an unbalanced load.

See the “**DAC-24 Operation**” section below for instructions on adjusting level for conditions other than 4 dBu reference with 20 dB headroom.

DAC-24 Operation

This section provides instructions for using the gain controls, aligning outputs, and adjusting the headphone monitor.

Using the Gain Controls

For setting left and right output levels, each output has its own level adjustment on the front panel. Outputs are factory-set for +4 dBu at -20 dBFS. Other levels can be set by using the following alignment procedure:

To align the left and right analog outputs:

1. Connect a reference digital tone generator to the DAC-24's **AES IN** connector.
2. Connect analog VU meters to the **LEFT OUT** and **RIGHT OUT** connectors.
3. Turn on the digital reference tone, and while metering the analog output levels, adjust the associated **L** and **R** trimmers for the desired output level.

Using the Headphone Monitor

The analog outputs may be monitored with a pair of stereo headphones plugged into the headphone jack. Best results are obtained with a headphone impedance of 20-50Ω. Use the associated stereo **VOLUME** control to set a comfortable listening level.

DAC-24 Interconnection

This section provides basic and advanced interconnection diagrams.

- **Basic — Monitoring Digital Signals**

In this basic application, connect the DAC to an AES patch panel. You can then quickly monitor the signal on any circuit, using either headphones or VU meters.

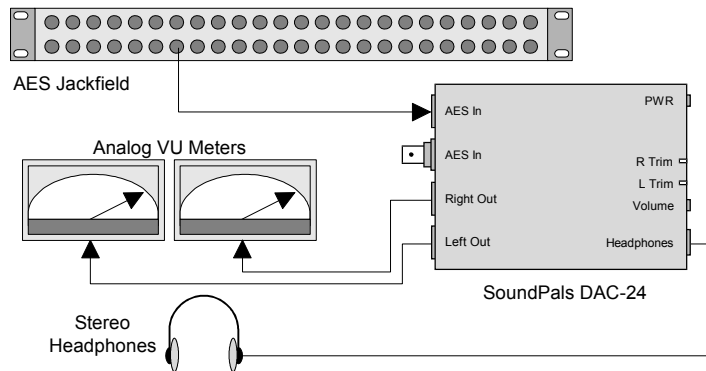

- **Basic — Inserting Analog Equipment**

In this application, an analog ATR is seamlessly inserted in a digital stream, using both the DAC and ADC together.

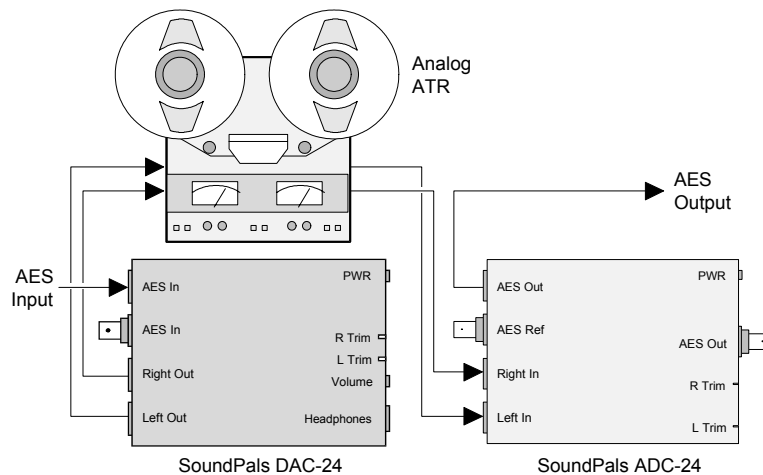

Advanced — Simultaneous Multi-Format Outputs

In this application, SoundPals are combined in a sub-mix configuration. A CD player feeds a DFADE for level control, and then a DMIX. Dual mics are converted to digital, routed to a DFADE for level control, and then to a DMIX. One DMIX output provides a digital feed, while the other is converted to analog using a DAC. Thus the mix is available in both analog and digital formats simultaneously.

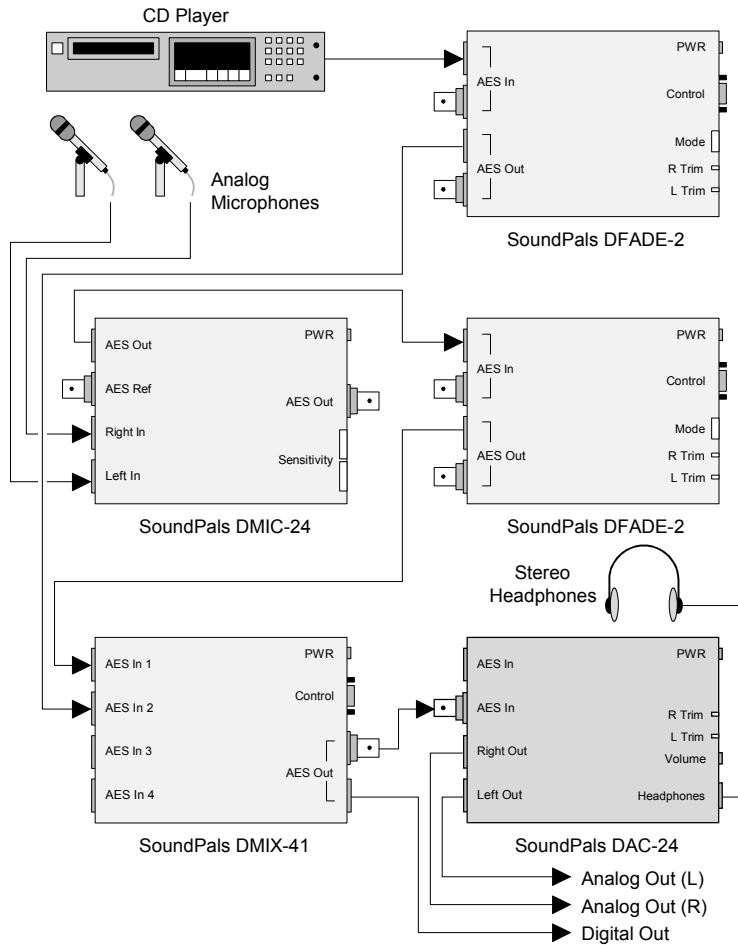

DAC-24 Internal Jumpers

This section provides information about the DAC-24's internal jumpers and adjustments.

NOTE For detailed instructions on opening and closing the DAC-24, see “Inside the Module.”

The figure below shows the DAC-24's internal jumper locations:

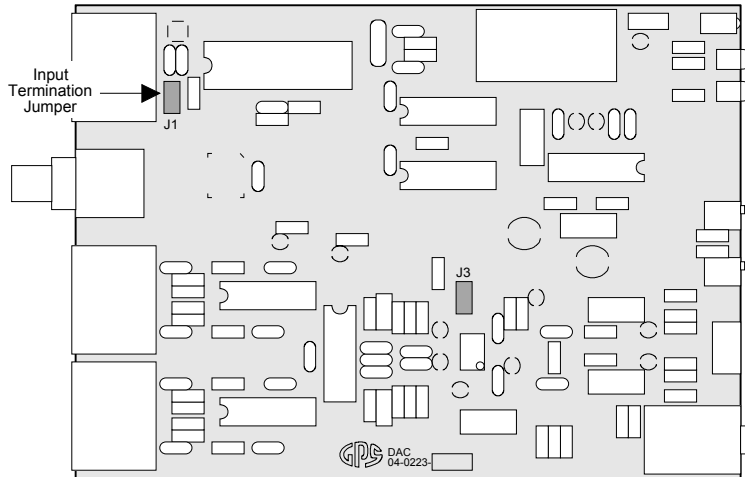

- To change the AES input from terminating to bridging, remove jumper **J1**.

DAC-24 Troubleshooting

The table below lists several DAC-24 problems, and provides a variety of “checklist” procedures designed to solve them.

Problem	Procedure
No signal at any analog output.	<ul style="list-style-type: none"> • Is power applied? Check the power LED and power supply. • Is a valid AES input signal connected? Check ERR LED off. • Is the input signal silent? Check the signal source.
No audio on XLR outputs.	<ul style="list-style-type: none"> • Are the outputs connected correctly? Check + to pin 2, to pin 3 (balanced) or hot to pin 2, ground to pin 1/shell, pin 3 open (unbalanced).
No audio on headphone output.	<ul style="list-style-type: none"> • Is the volume control turned up? • Is the phone jack connected correctly? Check left hot to tip, right hot to ring, ground to sleeve.
Emphasis on input is not corrected.	<ul style="list-style-type: none"> • Does AES channel status indicate emphasis? Check EMPH LED on. • Is the sampling frequency within 4% of 48 KHz, 44.1 KHz or 32 KHz? • Does the emphasis use 50/15 μs time constants?

NOTE Please contact the GPS factory if the problem still exists after completing the above procedures.

DAC-24 Specifications

This section provides audio and environmental specifications.

Audio Specifications

Parameter	Specification
Digital input	Terminated (110 Ω AES3, 75 Ω AES3id)
Sample Rate	30 KHz - 50 KHz
Analog Outputs	
Impedance	30 Ω
Level range	-5 dBu to 12 dBu at -20 dBFS
Maximum output	-87 dB THD+N
	+24 dBu (bridging load)
	+22 dBu (600 Ω load)
-20 dBFS @ +4 dB	-98 dB THD+N
Frequency response	+0/-0.2 dB, 20 Hz - 20 KHz
Crosstalk	<-84 dB, 20 Hz - 10 KHz
Dynamic range	100 dB
Headphone Output	
Impedance	20 Ω
Frequency response	+0/-0.2 dB, 50 Hz - 20 KHz
Dynamic range	91 dB
Options	
RT-2, 1RU rack tray for mounting up to 3 units	
Power supplies:	
<ul style="list-style-type: none">PSU-1, 90-260V 50/60Hz in-line power supply with detachable IEC power cord	

- NOTE**
- All specifications listed above subject to change without notice.
 - All parameters listed above specified at 48 KHz sampling frequency.

Environmental Specifications and Dimensions

Parameter	Specification
Dimensions (less connectors)	5.2W x 1.62H x 6.625D 13.2 x 4.1 x 16.8 cm
Power	375 mA @ 6Vdc
Operating Temp.	10 – 50 °C
Operating Humidity	10 – 90% RH non-condensing

Inside the Module

In This Section

This section provides instructions for opening and closing the SoundPals DAC-24 module to gain access to the internal circuit board.

NOTE The internal circuit board should only be removed from the module if you want to set the termination jumper.

Before You Begin

Check the following items before opening the module and attempting to remove the internal circuit board:

- If required, remove the SoundPals module from the rack tray.
- Disconnect the power supply from the front of the product.
- Disconnect all input and output cables.
- Perform the remaining steps *only* in a static free environment. Make sure that *you and the product* are both grounded.

The following tools are required:

- #2 Philips screwdriver

Opening the Module

Use the following steps to open the DAC-24 SoundPals module:

1. On the rear panel, remove the four Phillips screws from the four corners of the module.
2. On the rear panel, remove all Philips XLR mounting screws from the module.
3. On the rear panel remove the BNC nut and associated lock washer.
4. Remove the rear panel.
5. On the front panel, remove four Phillip screws from the four corners of the module.
6. Pulling the front panel, carefully draw the internal circuit board and front panel assembly from the housing.

CAUTION Keep the case horizontal so that the BNC bushing stays with the connectors.

7. Set the housing and all mounting hardware in a safe place.

Closing the Module

Use the following steps to close the DAC-24 SoundPals module:

1. Ensure that product label is on the bottom.
2. Carefully slide the internal circuit board and front panel assembly through the housing. Keep the case horizontal so that the BNC bushing stays with the connectors.
3. Replace, but do not tighten, the four Phillips screws in the front corners of the SoundPals module.
4. Replace the rear panel.
5. Replace, but do not tighten, the four Phillips screws in the rear corners of the SoundPals module.
6. Tighten the four front plate corner screws making sure that the plate is aligned with the housing. Repeat with the four rear plate corner screws.

7. Replace all Philips XLR mounting screws at the rear of the SoundPals module.
8. Replace the BNC nut and associated lock washer at the rear of the SoundPals module.

CAUTION Do not over tighten the screws.

External Power

About Power Supplies

An external power supply conforming to the specifications listed in the following “**Power Supply Specifications**” section *must be used* to guarantee that published SoundPals performance figures are met. Any power supply meeting these specifications will supply adequate power for a single SoundPals module. Although the specification is written for power supplies running from AC line inputs, DC (battery) sources may be used if they meet all of the listed requirements.

CE Compliance

For CE compliance, the power supply that you use *must comply* with the following requirements:

- Low Voltage Directive 73/23/EEC
- EMC Directive 89/336/EEC
- EMC Directive 93/68/EEC
- The connector locking ring must be tight.

Portable Power Sources

For portable SoundPals power sources, sealed lead-acid, nickel cadmium or alkaline primary batteries may be used. However, the maximum voltage must *not* exceed 8.6 volts, and a minimum of 5.6 volts is required for normal operation. Maximum current drain will be 400mA.

Power Supply Specifications

The following specifications must be met over all anticipated operating conditions including AC power line range, temperature range, etc.

Parameter	Specification
Output voltage	5.6V minimum (measured at trough of ripple) at 400 mA constant current. 8.6V maximum (measured at peak of ripple) at 262 mA constant current.
Ripple voltage	2V p-p at 700mA constant current. 400 mV p-p at 700mA constant current with external 2200 μ F capacitor.
Connector	Switchcraft 761K with center positive, sleeve negative.

Power Supply Sources

In addition to the GPS-supplied universal power supply, the following power supplies meet the SoundPals requirements:

Company	Model	Note
Stancor	STA-4860	120V AC, 60 Hz
Stancor	STAF-0797F	220V AC, 50 Hz with European wall plug (CE compliant).
Elpac	MI2007	95-250V AC, 47-63 Hz with IEC inlet (line cord required). Will power up to six units (CE compliant).