

VRG-1 User Guide

Video Reference Generator



Printing History

SoundPals™ VRG-1 Video Reference Generator

Rev. N/C

March 2007

Printed in U.S.A.

Part Number **08-2050-00**

The information contained in this guide is subject to change without notice or obligation.

Copyrights and Trademarks

© 2005 GRAHAM-PATTEN SYSTEMS, INC.

Contents of this publication may not be reproduced in any form without the written permission of Graham-Patten. Reproduction or reverse engineering of copyrighted software is prohibited.

FCC Compliance

This equipment has been tested and found to comply with the limits for a Class A digital device pursuant to Part 15 of the FCC Rules. These limits are designed to provide reasonable protection against harmful interference when the equipment is operated in a commercial environment. This equipment generates, uses, and can radiate radio frequency energy and, if not installed and used in accordance with the instruction manual, may cause harmful interference to radio communications. Operation of this equipment in a residential area is likely to cause harmful interference in which case the user will be required to correct the interference at your own expense.

Warranty Statement

Graham-Patten warrants that the equipment it manufactures is free from defects in workmanship and materials and meets applicable published specifications. Equipment that has been operated within published ratings and has not been subjected to abuse or modification, and which fails because of such defects, will be replaced or repaired at the Company's discretion if it is returned, freight prepaid, to Graham-Patten within seven years of receipt.

This warranty supersedes all other Warranties, express or implied. Graham-Patten is not liable for any consequential damages.

Company Address



GRAHAM-PATTEN SYSTEMS, INC.
119 East McKnight Way, Unit A
Grass Valley, California 95949
Telephone: (888) 622-4747, (530) 477-2984
Fax: (530) 477-2986
e-mail: info@isis-group.com
World Wide Web: www.gpsys.com

Graham-Patten is a division of



Table of Contents

Table of Contents	ii
Introduction	1
What are SoundPals?.....	1
Documentation Conventions.....	1
Signals and Values.....	1
Warnings.....	1
Unpacking and Inspection	2
Power Supply Note	2
VRG-1	3
About the VRG-1	3
VRG-1 Installation.....	5
Connecting Power	5
Connecting Reference Video Input	5
Connecting the AES and Word Clock Outputs	5
Connecting Alarm Output.....	5
VRG-1 Operation	6
VRG-1 Interconnection	7
Generating Reference for Analog to ADAT Conversion	7
Generating Reference for AES to ADAT Conversion	8
VRG-1 Troubleshooting	9
VRG-1 Specifications.....	9
Audio Specifications	9
Environmental Specifications and Dimensions	10
External Power	10
About Power Supplies	10
CE Compliance	10
Portable Power Sources	10
Power Supply Specifications	10
Power Supply Sources	11

Introduction

What are SoundPals?

Each Graham-Patten SoundPals module is essentially a digital audio *building block* that can be used independently, or interconnected to perform more advanced mixing and audio processing functions.

SoundPals can be used in both standalone and system configurations:

- In a “standalone” configuration, each SoundPals module is designed to perform a specific audio processing function such as ADAT-to-Analog conversion. In this way, each module functions as a perfect low-cost adjunct to larger mixing consoles (such as the Graham-Patten D/ESAM series) — for single-purpose processing tasks.
- In a “system” configuration, SoundPals can be *linked* to form more comprehensive digital audio tools. For field recording, studio applications, and workstation applications, SoundPals can be used to seamlessly perform functions that would otherwise require extensive peripheral gear. Best of all, SoundPals “systems” can be re-configured quickly and easily — to suit your changing audio production requirements.

All SoundPals modules are extremely compact, rugged, and identical in size for ease of installation, interconnection, and use. In addition, SoundPals support AES3id. This allows longer, more robust AES signal distribution using standard coaxial cable. Error free distances of 1000 feet can be attained using inexpensive coaxial cables.

Documentation Conventions

The following documentation conventions are used in this guide:

- Buttons, knobs, connectors, and switches are indicated in bold-faced capital letters. For example:

Adjust the left **GAIN TRIM** to ...

- Primary sections are listed in bold text, with a line above:

Primary Section

- Secondary sections are listed in bold text, with no line:

Secondary Section

Signals and Values

Note the following important information regarding audio signal level:

- 0dBu = 0.778Vrms
- AES3 = Balanced output with 2 channels of digital audio (left and right)
- AES3id = Unbalanced output with 2 channels of digital audio (left and right)
- Word Clock = 5V p-p square wave at the sampling frequency (32 KHz – 50 KHz). One edge of the square wave is used as the sampling reference.

Warnings

Please observe the following important warnings:

- Heed all warnings on the unit and in the instructions.
- Do not use this product in or near water.
- Route power cords and other cables so that they are not likely to be damaged. Disconnect power before cleaning. Do not use liquid or aerosol cleaners; use only a damp cloth.

Unpacking and Inspection

When you receive your SoundPals modules, inspect the cartons for signs of damage. Contact your dealer and the shipper *immediately* if you suspect any damage has occurred during shipping. Check the contents of each box to be sure that all parts are included. If any items are missing, contact your dealer immediately.

Power Supply Note

SoundPals are delivered with a power connector *only*. A separate power supply must be obtained. Graham-Patten offers several power solutions for both domestic and international customers. Refer to “**External Power**” for detailed power specifications for users who wish to configure their own power source, rather than purchase one from Graham-Patten.

VRG-1

Product Description

The **VRG-1 Video Reference Generator** is a SoundPals module that produces simultaneous AES, AES3id and Word Clock reference output signals at 48 KHz. These timing signals are derived from a standard NTSC or PAL reference video input, and are locked to that input. The VRG-1 also generates AES and Word Clock reference signals in the *absence* of a valid reference video input.

In any video production application, the VRG-1 is ideally suited to provide the required AES reference signal that allows you to lock the audio sampling rate to the video synchronizing rate. In a video facility, the VRG-1 would typically be locked to the system's master sync generator, and its output distributed to all digital audio devices. This connection thus ensures that each audio device is locked to the same reference — and also locked to the video.

The VRG-1 offers the following features:

- Simultaneous AES, AES3id and Word Clock outputs
- NTSC / PAL selectable
- External / Internal (free run) reference selection
- External / Internal LED indication
- Phase lock error LED indication
- Selectable mute upon loss of input reference video
- Alarm output, activated upon loss of input reference video
- Optional rack mounting tray (1 RU)
- Compact size, rugged construction

The figure below illustrates the VRG-1's front panel:

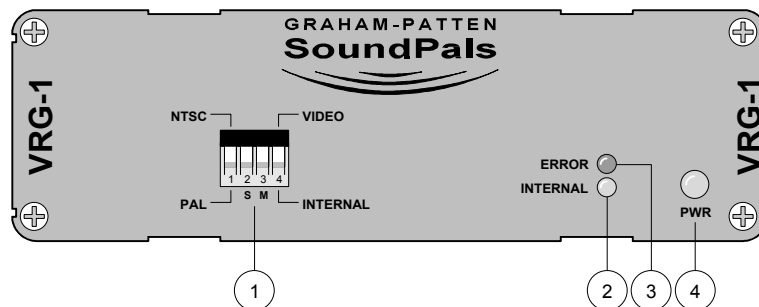

- 1) **Mode DIP Switch** — the 4-position **Mode DIP Switch (S1 through S4)** allows you to set the video standard (NTSC or PAL), select external or internal (free running) reference, and select whether or not the internal reference is *muted* when the external reference input is lost. Refer to the "**Using the Mode DIP Switch**" section for details.
- 2) **INTERNAL** — the green **Internal LED**, when lit, indicates that the VRG-1 is using its internal reference — either because the input reference signal is not present, or because **S4** is set to **Internal**.
- 3) **ERROR** — the red **Error LED**, when lit, indicates that the VRG-1 can not lock to the input video reference signal. This condition *may* be due to the incorrect setting of **S1 (NTSC/PAL)**, or due to an input video frequency that is out of the internal oscillator's lock range.
- 4) **PWR** — the green **Power LED** lights when power is applied.

The figure below illustrates the VRG-1's rear panel:

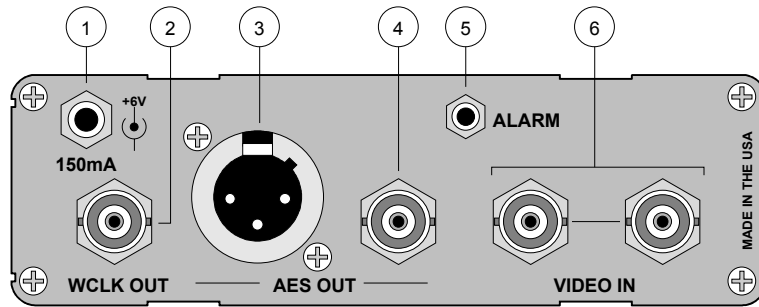

- 1) **Power Connector** — accepts the power jack from the 6VDC supply. Note the printed power rating (**150 mA**). Refer to “**External Power**” for more information on external power.
- 2) **WCLK OUT** — the **Word Clock Output** provides a 5 V p-p square wave at the sampling frequency (48 KHz). One edge of the square wave is used as the sampling reference. This output is typically used for devices such as workstations which do not provide an AES reference input. The Word Clock output is concurrent with the AES outputs — all can be used simultaneously.
- 3) **AES Balanced Output** — provides a balanced AES reference output via XLR. The output amplitude is 4.5 V p-p into 110Ω. The balanced output is concurrent with the unbalanced and Word Clock outputs.
- 4) **AES Unbalanced Output** — provides an unbalanced reference output via BNC (AES3id). The output amplitude is 1 V p-p into 75Ω. The unbalanced output is concurrent with the balanced and Word Clock outputs.
- 5) **ALARM** — when the input video reference signal is *not* present and switch **S4** is set to **Video**, the **Alarm** output provides a +5 volt signal capable of 25 mA. This voltage can be used as required to trigger an audible or visual alarm, an LED indicator or an opto-isolator.
- 6) **VIDEO IN** — standard loop-through BNC input connectors are provided for the *analog* reference video input signal (typically, black or black burst). Standard input termination rules apply. Refer to the “**Installation**” section for details.

Installation

This section provides instructions for connecting power, the reference input, the AES and Word Clock outputs, and the Alarm output.

Connecting Power

Plug a 6VDC power supply (rated at **150 mA** or greater) into the appropriate voltage outlet for *your specific country*, and connect the end of the cord into the jack marked **+6V**. Secure the locking ring finger tight. The green **PWR** LED lights when power is applied.

Connecting Reference Video Input

Use the following steps to lock the VRG-1 to your facility's house reference:

1. Connect a stable analog reference signal (such as **Black** or **Black Burst**) from your house sync generator to the left-hand **VIDEO IN** connector.
2. If the VRG-1 is the *last device* in your reference loop, terminate the right-hand **VIDEO IN** connector with a standard 75Ω terminator.
3. If the VRG-1 is in the *middle* of your reference loop, connect the right-hand **VIDEO IN** connector to the next device's reference input connector. Ensure that the reference loop is properly terminated at the end.

Connecting the AES and Word Clock Outputs

Connect the AES and Word Clock reference outputs to the reference inputs of those specific devices that require an AES reference signal. All reference outputs can be used simultaneously.

- For audio and video devices that require a balanced AES reference, use the VRG-1's **AES Balanced Output** (XLR).
- For devices that require an unbalanced AES3id reference, use the VRG-1's **AES Unbalanced Output** (BNC).
- For devices (such as computer workstations and ADAT devices) that require a Word Clock reference instead of AES, use the VRG-1's **Word Clock Output** (BNC).

Connecting the Alarm Output

In the event that the input video reference signal is lost, the Alarm Output provides a voltage that can be used to trigger an audible or visual alarm.

- By default, the output is open when reference video is present.
- When input reference is lost (and switch **S4** is set to **Video**), the output provides a +5 volt signal capable of 25 mA.

Using a customer supplied cable (typically, twisted pair) and 3.5 mm jack, connect the jack's **+** and **-** terminals to the proper terminals of your customer-supplied fault indicator, such as a light or a buzzer.

Operation

This section provides instructions for using the 4-position Mode DIP Switch on the front panel of the VRG-1.

Using the Mode DIP Switch

The 4-position **Mode DIP Switch** allows you to set the video standard, external or internal reference, and whether or not the internal reference is *muted* when external reference is lost. This is the *only* operational control on the VRG-1.

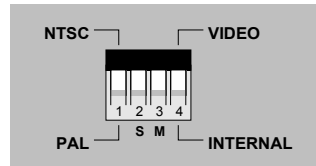

Set the DIP switches as required for your particular mode of operation:

- **Video Standard** — set switch **S1** to match the video standard of your facility — either **PAL** (625/50) or **NTSC** (525/60):
 - ~ Up = **NTSC**
 - ~ Down = **PAL**
 - **Spare** — this switch is not implemented. Leave switch **S2** in the **Up** position.
 - **Mute** — set switch **S3** to determine how the VRG-1 behaves when the external input video reference signal is lost. Note that switch **S4** must be set to **Video** for this mode to operate as described below:
 - ~ Up = **Normal**. The system automatically switches to internal reference when the external reference signal is lost or absent. In this mode, the 48 KHz reference is free-running based on the internal crystal.
 - ~ Down = **Mute**. The system mutes (shuts off) all reference outputs when the external reference signal is lost or absent.
- NOTE** If switch **S4** is set to **Video** and the **Alarm** output is properly connected, the alarm will trigger upon loss of input video. In addition, the green **INTERNAL** LED will light.
- **Reference Select** — set switch **S4** to determine whether video is locked to incoming reference or free-running:
 - ~ Up = **Video**. The system locks to the incoming reference signal. If the external signal is lost or absent, all switch **S3** modes apply.
 - ~ Down = **Internal**. The system switches to internal reference and runs unlocked at 48 KHz. Switch **S3** modes do *not* apply, but the green **INTERNAL** LED will light.

In general, the default mode of the VRG-1 is as follows:

- **S1: Up or down**, depending upon your facility standard.
- **S2: Up** (spare)
- **S3: Up** (automatic switch to internal upon loss of input)
- **S4: Up** (system locks to input video reference)

Interconnection

This section provides two VRG-1 interconnection diagrams. Each diagram illustrates an application that combines an audio workstation, the VRG-1, plus two of the four Graham-Patten SoundPals modules that utilize the ADAT (Alesis Digital Audio Tape) format. Note that the VRG-1's Alarm Output is not shown in either diagram.

- **Generating Reference for Analog to ADAT Conversion**

In this configuration, a dedicated 4-channel analog VTR (VTR-1) provides the audio signals that are digitized through the ADAT-1. This source VTR *also* provides the analog reference that locks the ADAT-1 via the VRG-1, thus synchronizing its signals to video. The ADAT-2 converts the audio back to analog format for recording on VTR-2.

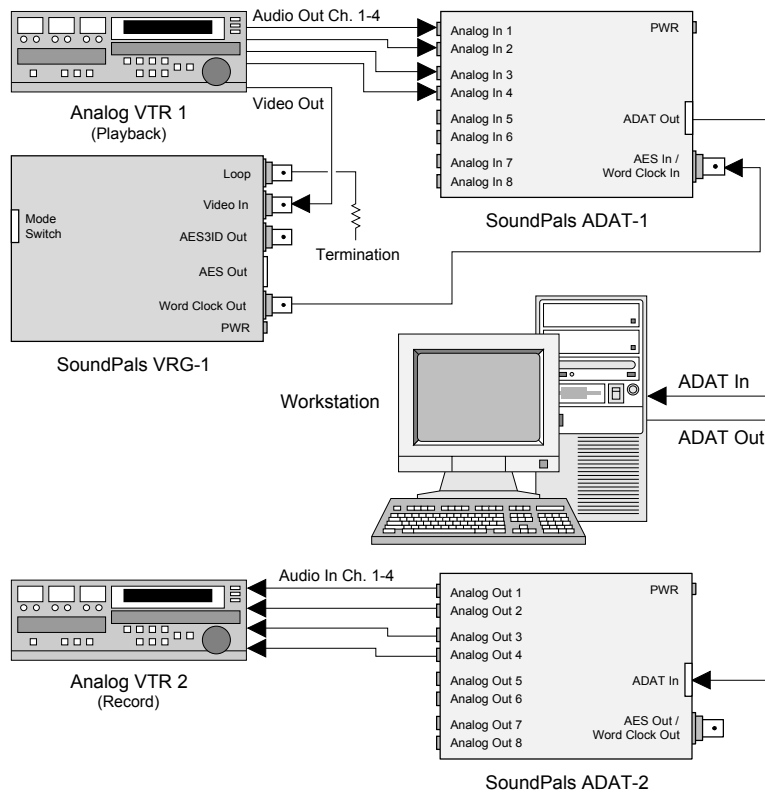

- Generating Reference for AES to ADAT Conversion**

In this configuration, 4 AES channels (from a facility routing switcher or patch panel) are routed to the ADAT-3 for conversion to the ADAT format. A standard analog house reference signal (from a routing switcher or a dedicated feed) provides the video that locks the ADAT-3 via the VRG-1, thus synchronizing the AES signals to video. Once the segment is completed on the workstation, the ADAT-4 converts it back to AES format, for routing in the facility.

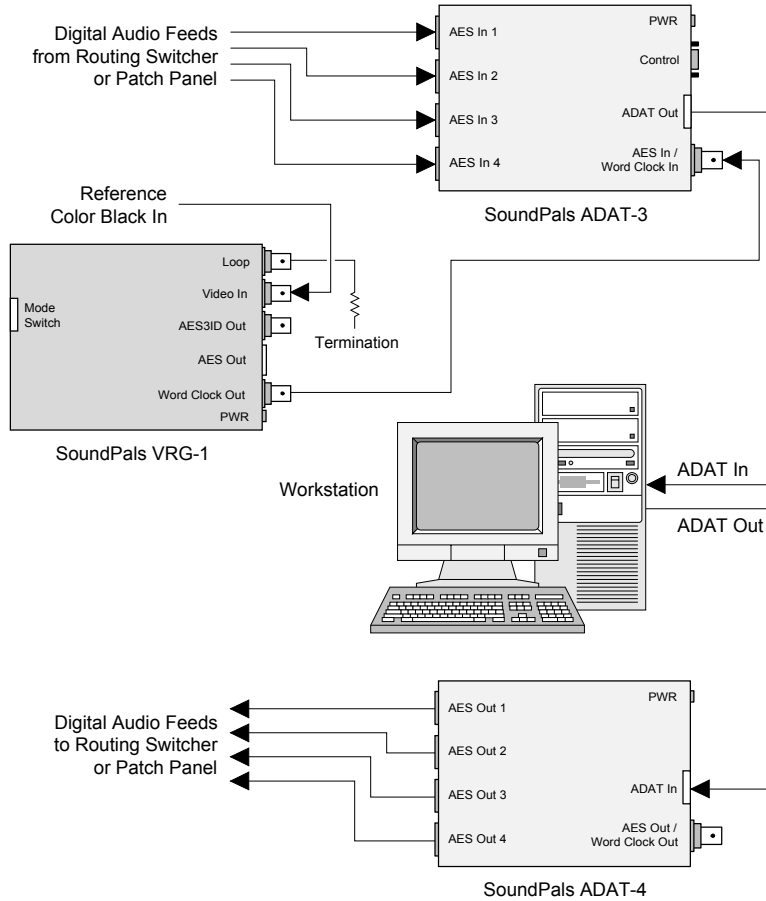

Internal Jumpers

There are no internal jumpers in the VRG-1.

Troubleshooting

The table below lists several VRG-1 problems, and provides a variety of “checklist” procedures designed to solve them.

Problem	Procedure
Power LED does not light, no outputs.	<ul style="list-style-type: none">• Ensure wall supply is plugged in properly and power connection is tight, not loose.• Check voltage from wall power supply for minimum 6 volts DC. Measure voltage at the supply connector, when disconnected from the DTG.

Specifications

This section provides VRG-1 audio and environmental specifications.

Audio Specifications

Specification	
General	
Video Input	Min. 0.25 volt p-p sync component
	Max. 2 volts p-p sync or video
Freq. lock range	+/- 200 ppm
Alarm output jack	3.5 mm
Reference Outputs	
AES output	4 volts p-p balanced 110 ohms (XLR)
AES3ID output	1 volt p-p 75 ohms (BNC)
Word Clock output	4.5 –5 volts p-p (BNC)
Options	
RT-2, 1RU rack tray for mounting up to 3 units	
Power supplies: <ul style="list-style-type: none">• PSU-1, 90-260V 50/60Hz in-line power supply with detachable IEC power cord	

NOTE All specifications listed above subject to change without notice.

Environmental Specifications and Dimensions

Parameter	Specification
Dimensions (less connectors)	5.2W x 1.62H x 6.625D 13.2 x 4.1 x 16.8 cm
Power	<150 mA @ 6Vdc
Operating Temp.	10 – 50 °C
Operating Humidity	10 – 90% RH non-condensing

External Power

About Power Supplies

An external power supply conforming to the specifications listed in the following “**Power Supply Specifications**” section *must be used* to guarantee that published SoundPals performance figures are met. Any power supply meeting these specifications will supply adequate power for a single SoundPals module. Although the specification is written for power supplies running from AC line inputs, DC (battery) sources may be used if they meet all of the listed requirements.

CE Compliance

For CE compliance, the power supply that you use *must comply* with the following requirements:

- Low Voltage Directive 73/23/EEC
- EMC Directive 89/336/EEC
- EMC Directive 93/68/EEC
- The connector locking ring must be tight.

Portable Power Sources

For portable SoundPals power sources, sealed lead-acid, nickel cadmium or alkaline primary batteries may be used. However, the maximum voltage must *not* exceed 8.6 volts, and a minimum of 5.6 volts is required for normal operation. Maximum current drain will be 160mA.

Power Supply Specifications

The following specifications must be met over all anticipated operating conditions including AC power line range, temperature range, etc.

Parameter	Specification
Output voltage	5.6V minimum (measured at trough of ripple) at 160 mA constant current. 8.6V maximum (measured at peak of ripple) at 105 mA constant current.
Ripple voltage	2V p-p at 700mA constant current. 400mV p-p at 700mA constant current with external 2200µF capacitor.
Connector	Switchcraft 761K with center positive, sleeve negative.

Power Supply Sources

In addition to the GPS-supplied universal power supply, the following power supplies meet the SoundPals requirements:

Company	Model	Note
Stancor	STA-4860	120V AC, 60 Hz
Stancor	STAF-0797F	220V AC, 50 Hz with European wall plug (CE compliant).
Elpac	MI2007	95-250V AC, 47-63 Hz with IEC inlet (line cord required). Will power up to six units (CE compliant).